

Chapter Four —CASTER POWER-BACK AND INDICATION SYSTEM

The Caster Power-Back System provides the capability of free-castering the Aft MLGs. Castering the Aft MLGs with the forward MLGs locked, facilitates ground maneuvering of the aircraft. Free-castering is initiated by a free-caster switch located on the center console. Indication of NLG and MLG position is provided by individual indicators. The landing gear indication system is independent of the positioning system and indicates the position of the respective landing gear at all times.

Built-in Test Equipment (BITE) allows the system to be checked for fault conditions in each of the line replaceable units (LRUs).

Emergency positioning control of the aft MLGs is provided by individual positioning switches on the copilots side panel. The forward MLGs remain in a fixed zero position by two large interconnected rods. See figure 4-5.

System LRUs

- ◆ Freecaster/Powerback box
- ◆ Positioning manifold
 - Bypass valves
- ◆ Shutoff valves
- ◆ Powerback positioning actuators
- ◆ Electro hydraulic valves (EHV)
- ◆ Bypass pilot valve
- ◆ Bypass solenoid pressure switch
- ◆ Shutoff pilot valves
- ◆ Synchro position transmitter
- ◆ Right MLG position indicator (dual)
- ◆ Left MLG position indicator (dual)
- ◆ Linear Variable Differential Transformers (LVDT)

SYSTEM SPECIFICATIONS

Free castering of the aft MLG is up to 20° left or right of center. The gears are powered to center by interlocks and the caster/powerback drive circuits.

LRU DESCRIPTION

FREE CASTER/POWERBACK BOX—The caster/powerback box, located at FS 1480 RH, monitors and controls the aft main landing gears during powerback when commanded to center from the free caster mode. During powerback the box will sense gear direction and speed, and will prevent an asymmetry powerback condition from occurring.

The caster/powerback box is mounted on the right cargo sidewall just aft of the wing box beam section. The box contains five circuit cards identified as A1 through A5, one of which is a spare, a mother board A6, and five relays, K1 through K5. On the right-hand side of the control box is a small panel that contains the built-in test equipment (BITE) control switch and the BITE indicator lights.

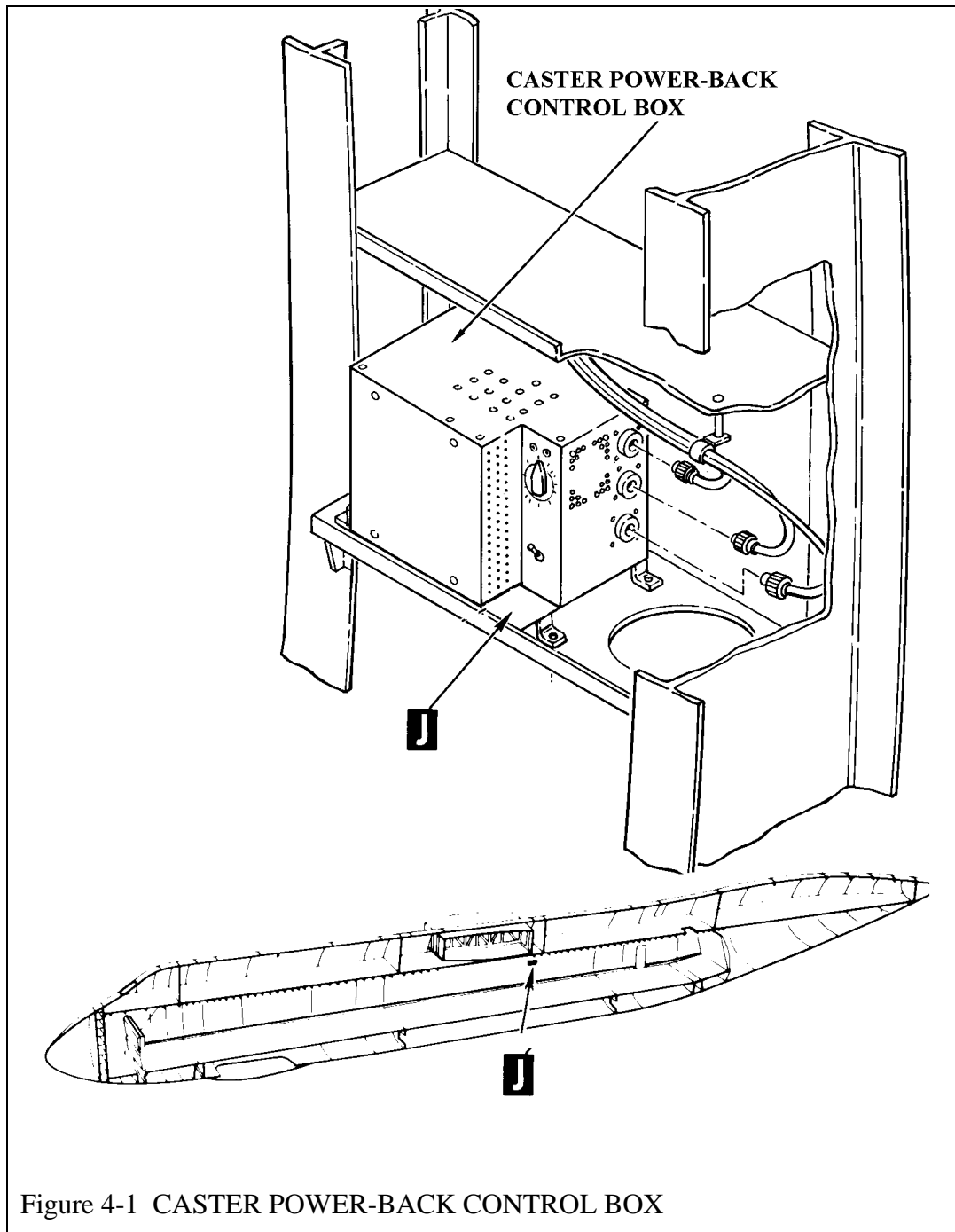

Figure 4-1 CASTER POWER-BACK CONTROL BOX

AFT MLG POWER-BACK POSITIONING MANIFOLD—The positioning manifold is located on the crosshead of the MLG strut, just below the emergency rotation cylinder assembly. The manifold contains the electro-hydraulic servo valve (EHV) and the bypass valve. The manifold controls fluid pressure and flow to the powerback positioning cylinders. See figure 1-13.

MLG ELECTRO-HYDRAULIC SERVO VALVE (EHV)—The EHV's are located one per MLG bogie in the powerback positioning manifold. The EHV consists of an electrically operated motor driving a hydraulic servo valve. See figure 1-13.

The servo valve is installed in line with the pressure/return lines to two powerback positioning hydraulic cylinders. The torque motors of the EHV's receive signals from the caster/powerback box. The direction and rate at which the valve moves is determined by the polarity and amplitude of the caster/powerback drive signal respectively. The valve is normally centered in the off position—pressure and return lines blocked. When it receives a signal at the proper amplitude, it will move to one of two positions—PRESSURE or RETURN LINES OPEN—depending on the polarity of the drive signal. In one position, the cylinders will cause the MLG bogies to rotate clockwise. In the other position, the cylinders will rotate the MLG bogies counterclockwise. The valve controls the pressure and flow to the two powerback positioning cylinders on the respective landing gear. After the cylinders have driven the bogie to the powerback center position, power is removed from the torque motors of the EHV's.

BYPASS PILOT VALVES—The bypass pilot valves are located in the cargo compartment at FS Station 1535 LT and RT. The valves are electrical energized when the caster switch is placed to caster. This action provides hydraulic pressure

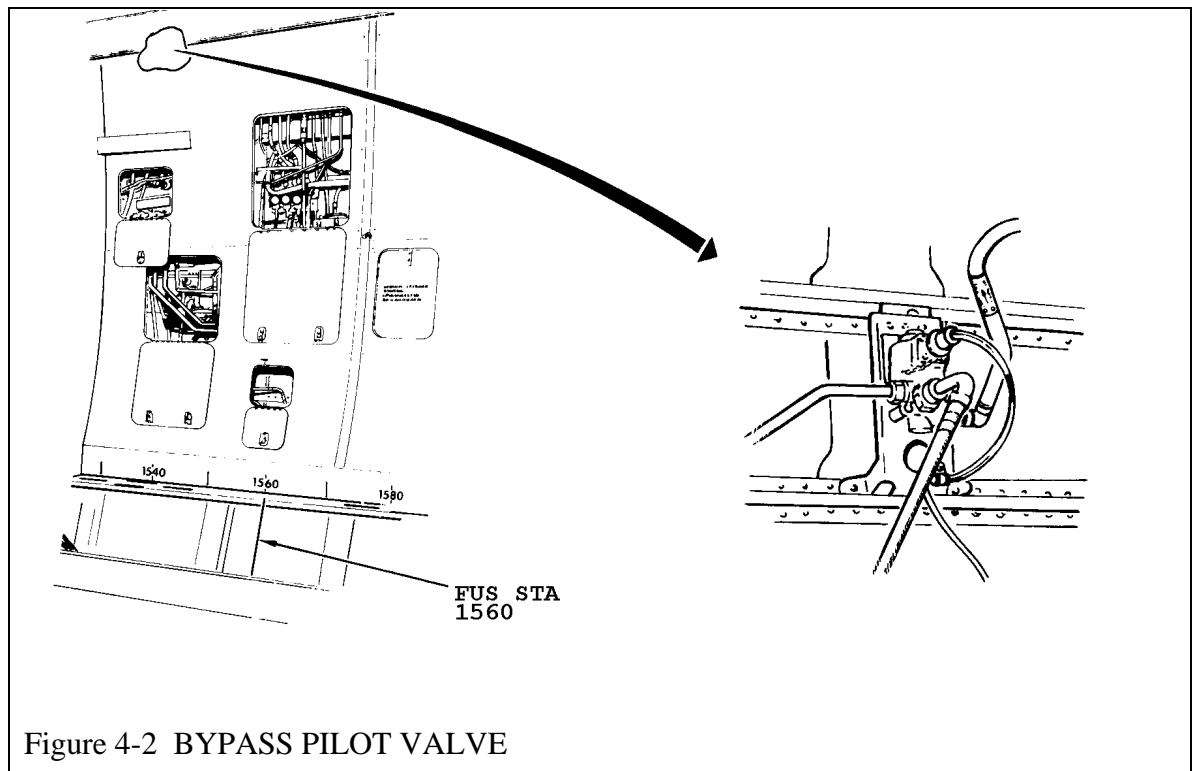

Figure 4-2 BYPASS PILOT VALVE

to the bypass pressure switch and the bypass valve. This action places the bypass valve in a run-around condition. The bypass valve is located in the positioning manifold.

BYPASS VALVES—The bypass valves are hydraulically operated valves located within the positioning manifold assembly. The bypass valves are hydraulically situated between the EHV's and the positioning cylinder shutoff valves. See figure 1-13. The normally open bypass valves are hydraulically energized to a bypass condition under any one of the following conditions:

- ◆ Bypass pilot valve is energized.
- ◆ Emergency system isolation valve and either the emergency outboard positioning and emergency rotation solenoid valve or the emergency inboard positioning solenoid valve are energized.

When energized, the bypass valves will place the positioning cylinders in a hydraulic run-around condition, provided the hydraulically energized shutoff valves are energized.

LINEAR VARIABLE DIFFERENTIAL TRANSFORMER (LVDT)—The linear variable differential transformers (LVDTs) are electric mechanical devices that operate similarly to an E pick-off. The LVDT contains a transformer with two secondary windings and a movable core. The LVDT housing is cylindrical in shape with a shaft extending from it. This shaft is connected to the movable core of the internal transformer. The shaft is free to move linearly into and out of the LVDT housing and is attached to the moving rod of the powerback positioning cylinder. Electrically, the LVDTs translate the linear travel of the positioning cylinder rod to an electrical signal representing degrees of bogie rotation. Two LVDTs are mounted on each aft MLG. One is used as the position feedback device (control LVDT) for the MLG servo loop, while the other LVDT (monitor LVDT) provides comparison position information to the powerback box for asymmetry detection. See figure 1-13.

NOTE: The control LVDT is the right hand LVDT facing inboard at any given bogie.

SHUTOFF VALVES—Normally closed shutoff valves are located in the pressure and return lines of each powerback positioning cylinder. The valves, one located on top of each positioning cylinder, are used to block the positioning cylinders hydraulically. The cylinders lock the bogie in a given position. The valves are actuated by pilot pressure from either the shutoff pilot valve or the emergency pilot blocking valve. A switch is located on each shutoff valve to provide interlock information to the system.

See figure 1-13.

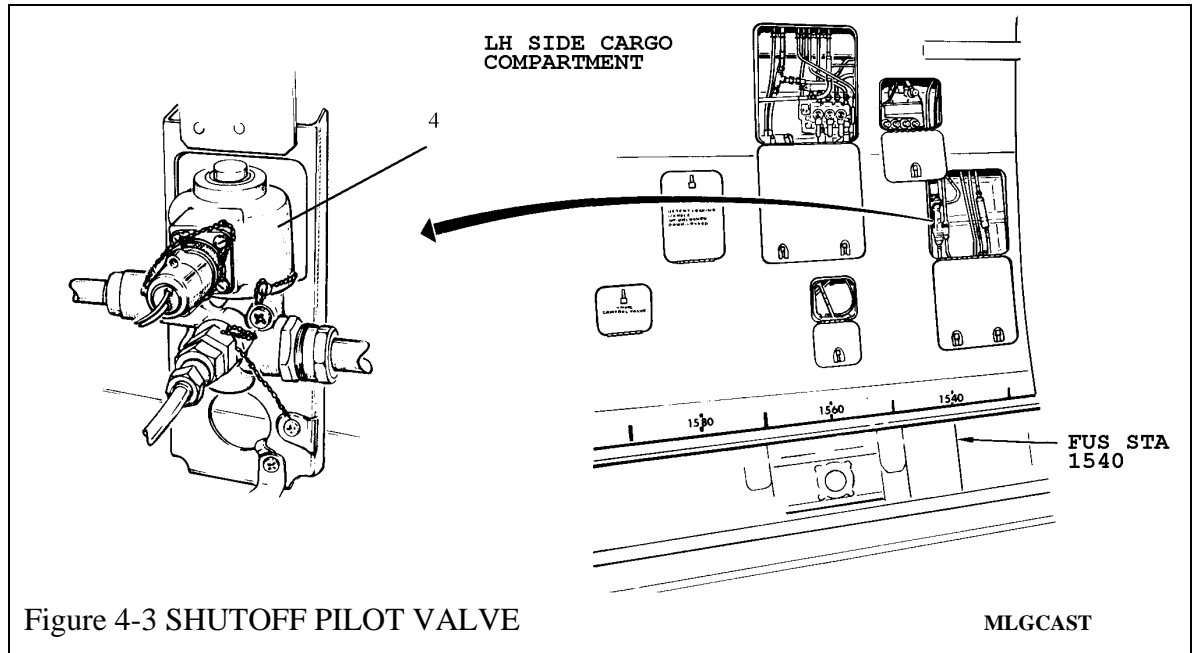

Figure 4-3 SHUTOFF PILOT VALVE

MLGCAST

SHUTOFF PILOT VALVE—The shutoff pilot valves are located in the respective aft MLG down line adjacent to the control manifold for each gear. When energized electrically from the caster/powerback box controlled MLG SOV control relays, the valves provide hydraulic pressure to actuate the positioning cylinder shutoff valves in the MLG wheel well area. See figure 4-3.

SYNCHRO TRANSMITTERS—The MLG synchro transmitters, one located on top of each strut, are driven by a three to one step up gearing which causes the associated indicator pointer to drive three degrees for each actual degree of MLG bogie rotation. Twenty degrees of caster positioning of the MLG bogies corresponds to 60° of actual movement of the indicator pointer. The MLG position transmitters receive their power in parallel with the MLG position indicators. See figure 1-13.

CASTER ADVISORY LAMPS—Directly above the NLG steering system pressure select switch are two advisory lights. During the caster mode, the two lamps come on to advise the pilot that the two aft MLGs are free to caster. These lamps are labeled: LEFT AFT MLG FREE and RIGHT AFT MLG FREE. See figure 4-5.

MLG POSITION EMERGENCY CONTROL PANEL—Located on the panel are two dual pointer MLG position indicators. In addition, two emergency bogie rotation switches are installed on the panel. The left aft MLG switch is mounted directly under the left MLG position indicator and the right aft MLG is mounted under the right MLG indicator. See figure 4-5.

The indicator is a round dial, clamp-mounted type with dual pointers and synchros. The two pointers are associated with the two gears by a letter “F” meaning forward and “A” meaning aft printed on the appropriate pointer. The dial scale is calibrated from 0-degrees at the 12 o’clock position to 20-degrees left and from 0-degrees to 20-degrees

right. The dial for the left indicator contains a 90-degree calibration mark at the 9 o'clock position. The purpose of the 90-degree mark is to indicate that the gear has rotated 90-degrees inboard during retraction. The right MLG indicator has this 90-degree mark located at the 3 o'clock position on the dial. The position indicators and their transmitters receive 115 Volts AC, 400 Hz power from the FWD MAIN AC BUS NO.1 (FLT ENGR CKT BKR PNL NO. 4) through the MLG POS IND LH and MLG POS IND RH circuit breakers.

These switches provide an emergency rotation capability if the caster/powerback system should fail and disconnect. The affected aft gear may be rotated back to center with the emergency rotation switch.

FREE CASTER SWITCH—The free caster switch on the center console is actuated during ground maneuvering if required. In the CASTER position, the aft MLG bogies are free to caster in response to ground loads. Actuation of the switch opens the aft gear shut-off valves and actuates the by-pass valve solenoid. Hydraulic fluid bypasses the aft MLG positioning cylinders and enables the aft MLG to move without restraint. Two indicator lights (LEFT AFT MLG FREE, RIGHT AFT MLG FREE) located on the center main instrument panel illuminate when in the free caster mode. In the CENTER position, the aft MLG bogies are driven back toward the center position. After the MLG bogies reach the center position, the MLG free lights go out. See figure 4-5.

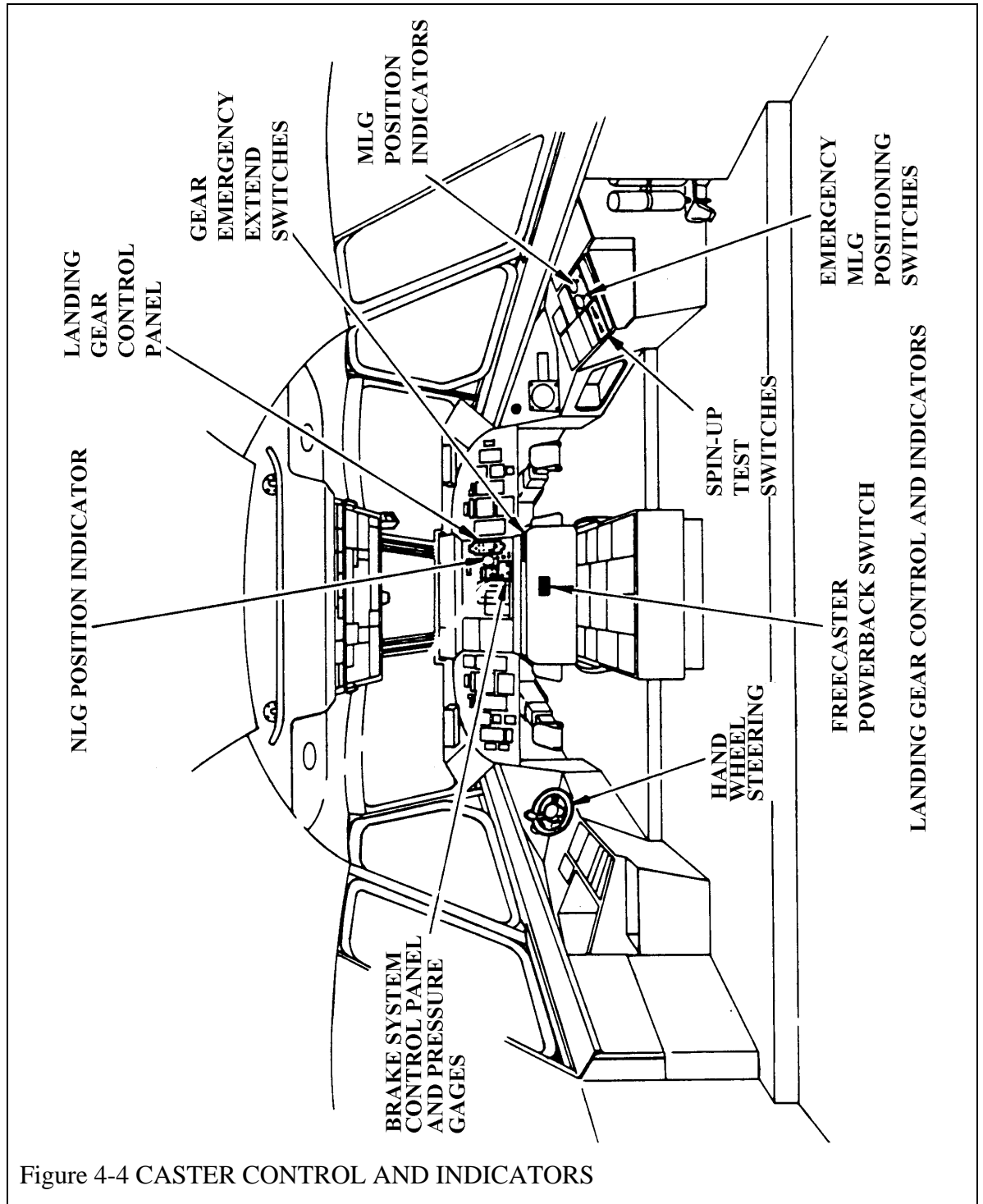

Figure 4-4 CASTER CONTROL AND INDICATORS

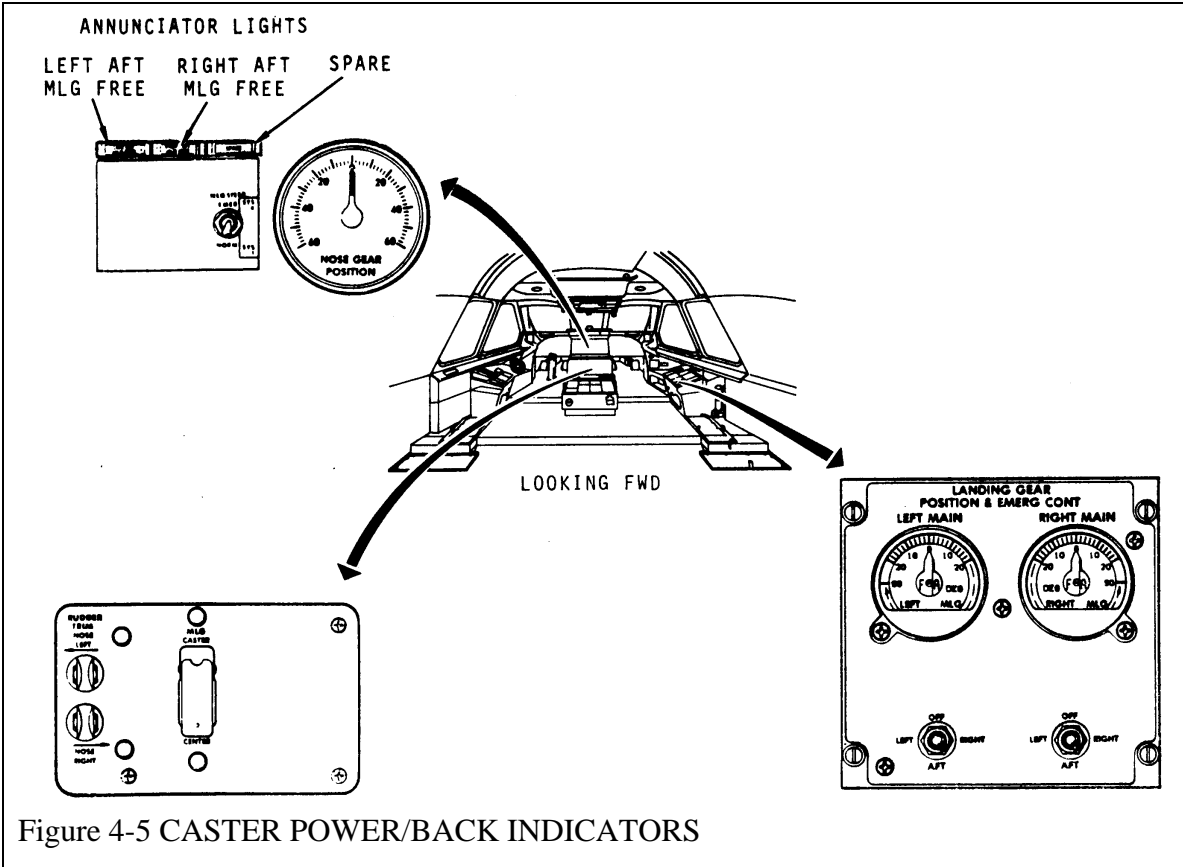

Figure 4-5 CASTER POWER/BACK INDICATORS

CASTER/POWERBACK SYSTEM ELECTRICAL

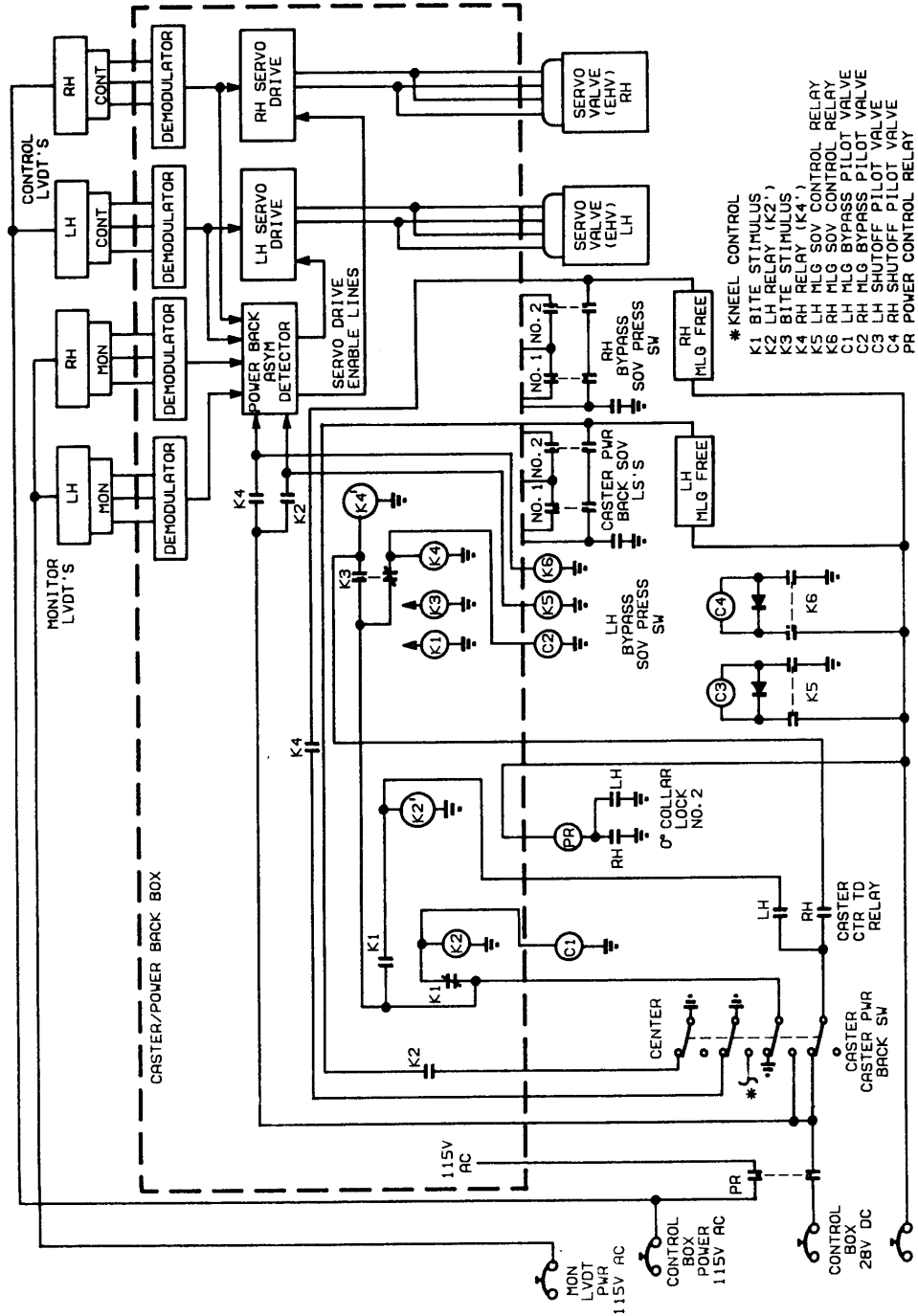

Figure 4-6 CASTER/POWERBACK SYSTEM ELECTRICAL

CASTER/POWERBACK HYDRAULIC SYSTEM

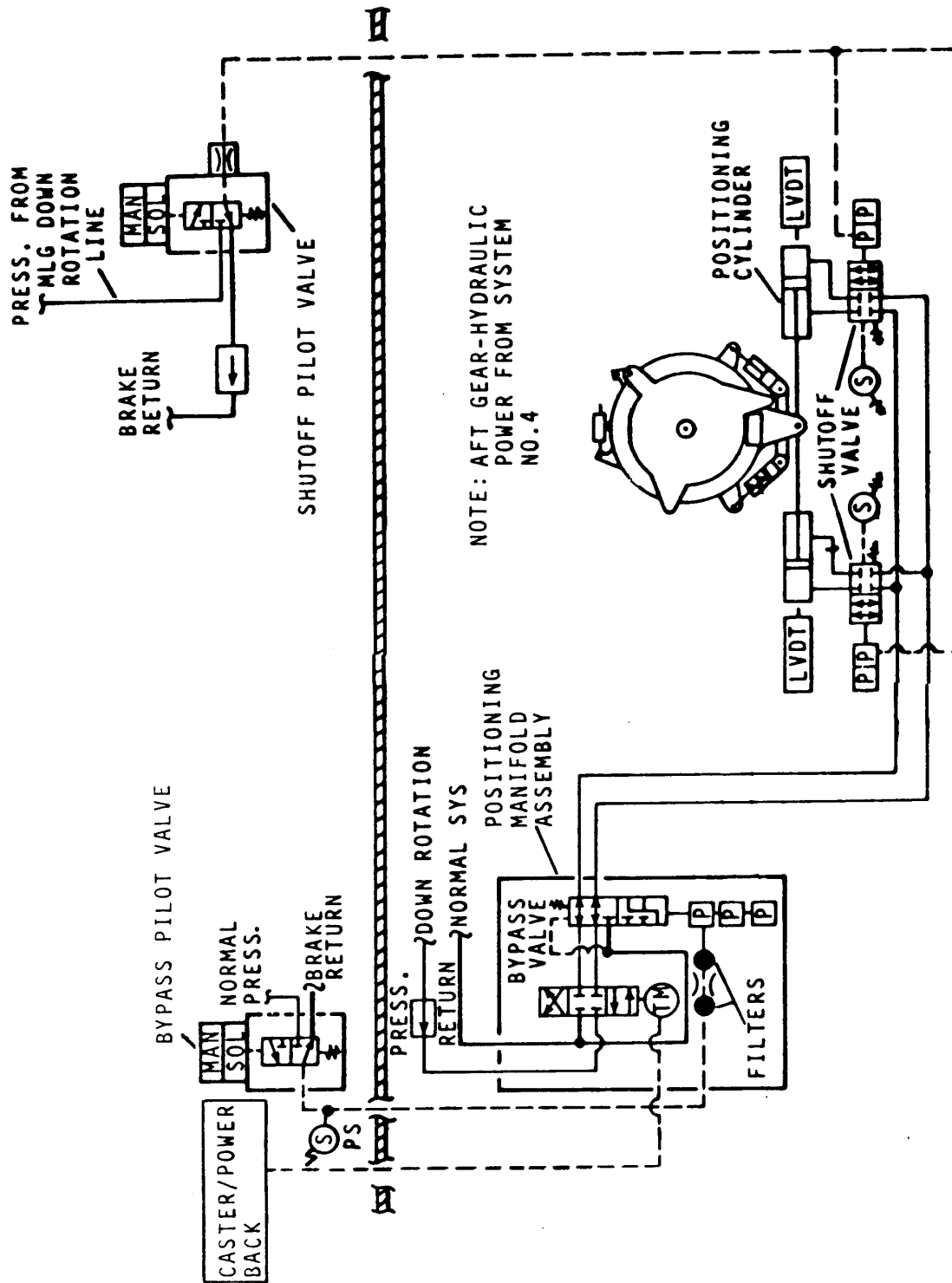

Figure 4-7 CASTER/POWERBACK HYDRAULIC SYSTEM

AFT MLG CASTERING MODE—The castering mode is discussed as two sub-modes. To unlock and free the aft gears one set of interlocks is required. Power back from castered positions requires another set of interlocks. The caster mode is initiated when the caster/powerback system is in the legitimate command position. That is, when the aft gears are normally locked, and when it is desired to free the aft MLG so that they can caster to follow nose wheel steering. See figures 4-6 and 4-7.

When the caster control switch is selected to CASTER position the K2 and K4 relays are re-energized. The shutoff pilot valve solenoid is energized allowing hydraulic pilot pressure to place the positioning cylinder shutoff valves to bypass. The bypass pilot valve solenoid is energized and hydraulic pressure positions the bypass valve. The positioning manifold of the aft MLGs allows the positioning cylinders on the aft MLG to assume a hydraulic run-around condition.

The associated aft MLG free light comes on when the respective shutoff valve limit switches are closed and the bypass pilot valve pressure switch is closed.

The system is designed to monitor and maintain a safe powerback operation of the aft MLG from the free caster operation. When a difference of 8° is reached between the aft gear during powerback, the leading gear system shuts down. The lagging gear continues to drive to within 5° of the leading gear before the two gears will continue driving.

POWERBACK MODE—Placing the caster switch to the CENTER position causes the right and left MLG bypass pilot valves to de-energize and remove pilot pressure from the bypass valve in the position manifold. The caster/powerback computer then signals the servo valves in the positioning manifold to center the gear. The aircraft must be moving during powerback mode to avoid stress on the MLG.

After the gear reaches center a signal is sent to the computer, which removes power from the servo valve. The right and left shutoff pilot valves de-energize allowing the shutoff valves (blocking valves) to close, locking the gear in place. The switches on the shutoff valves reposition to turn off the MLG FREE lights on the annunciator panel.

During power back operation, the computer is controlling the servo valve and as the gear is rotated to center, the direction and speed is being determined by input signals from the LVDT sensors attached to the gear. The control circuits include an asymmetry circuit that stops operation of a gear that advances more than 8° ahead of the other. The asymmetry circuit allows operation of the stopped gear when the other gear catches up to within 5° .

CASTER/POWERBACK BITE SYSTEM—The BITE system controls and indicators consist of a BITE selector switch, a rotary switch, and two indicator lights (L pass and R pass). A placard of operating instructions is installed on the face of the box.

The caster powerback BITE system will check:

- ◆ Ability to engage at various levels.
- ◆ Asymmetry shutdown.
- ◆ Sum error detection.

- ◆ LVDT agreement between the control and monitor.
- ◆ LVDT power.
- ◆ Shutoff valve function.
- ◆ BITE circuits.

To perform a BITE check, the free caster switch is in CASTER and hydraulic system No.1 is pressured. While holding the momentary BITE switch in the UP position, set the rotary switch to positions No.1 through 20 in sequence. Results: positions 2 through 18 pass lamps ON and positions 19 and 20 pass lamps OFF. Release momentary switch and position rotary switch to OFF. If the results of the BITE check were unsatisfactory, refer to T.O. 1C-5A-2-10FI-1-2 for troubleshooting procedures.

THEORY OF OPERATION—The caster/powerback control box receives 115-Volt AC and 28 Volts DC power through the energized contacts of the power control relay. The power control relay (PR) is energized only when the zero degree collar lock relays for the right and left aft MLG ARE ENERGIZED. This ensures the aft MLG are rotated and locked to the zero degree position. The LH and RH centered time delay (TD) relays are energized in this condition. With the center/caster switch in CENTER position, TD relays provide 28 VOLTS DC power to energize relays K2 and K4 to the X side. These magnetic latching relays remain in the state to which they were last energized. In this condition, the left and right aft MLG shutoff pilot valves are de-energized, closing the shutoff (blocking) valves, locking the MLG in the center position.

Selecting CENTER after caster operation de-energizes the coils of K2 and K4; however, they do not change position since they are magnetic latch relays. Left and Right MLG bypass pilot valves de-energize, removing pilot pressure to the bypass valve in the positioning manifold. The caster/powerback box now operates the servo valves through the bypass valves for positioning cylinder operation.

The LVDTs provide control and monitoring signals for powerback operation. Note that 115-Volt AC excitation power from the aircraft bus is applied to the LVDTs any time power is applied to the aircraft buses. The LVDTs are electromechanical devices that operate similar to an E pick-off. The LVDT translates the linear travel of the positioning cylinder ram to an electrical signal representing degrees of bogie rotation. Two LVDTs are mounted on each MLG. The control LVDTs provide the feedback signal for the MLG servo loop while the monitor LVDT provides comparison position information to the control box for asymmetry detection. The asymmetry circuit compares left and right MLG position during powerback operation and will interrupt the motion of either gear if one gear leads the other by more than 8°, and allows the motion to resume when the difference is 5° or less.

A redundant asymmetry circuit is included for fail safe operation, and either pair of circuits can interrupt the motion of an asymmetrical gear. An additional circuit monitors the direction of the output drive signal, and if the monitor and control signal do not agree, motion is inhibited.

The final sequence takes place when the gear reaches the centered position. A 1.75-second time delay centering relay is energized and in turn energizes K2 and K4 latching coils. This opens K2 and K4 contacts, which de-energize the Left and Right MLG SOV Control Relays. With the opening of the Left and Right MLG SOV Control Relays contacts, the Left and Right shutoff pilot valves de-energize. The positioning cylinder shutoff valves close, blocking the positioning cylinders in a centered position. With the opening of K2 and K4 contacts, the two AFT MLG FREE annunciator lights go out and power is removed from the powerback asymmetry modules. The bogie position indicators display zero degrees.

Chapter Five —KNEELING SYSTEM

The aircraft kneeling system enhances cargo loading and unloading operations. The system includes three kneeling modes: level, forward (nose down), and aft (tail down). The main and nose gears are knelt together to provide the desired cargo floor height which best suits the loading and/or unloading operation. See figure 5-3.

The NLG is kneeled or unkneeled by using the normal NLG retraction and extension system. MLG kneeling or unkneeling operations are provided by four hydraulic motors, one mounted to each MLG yoke.

The kneeling system is electrically controlled from the kneeling control panel located at the flight engineer's station.

Individual MLG kneeling is available inflight for emergency purposes and available on the ground for maintenance purposes such as changing a wheel and tire assembly.

A pointer and decal for visual indication of proper NLG strut extension is located on the left side of the NLG scissors. The pointer must indicate in the green. A strut limiter is used during forward kneeling operations to restrain strut extension. See figure 5-1.

There is no electrical interlock for center position of the NLG before a kneeling operation is initiated. A visual check for center position is accomplished by viewing the pointer and degree indicator located at the NLG.

NLG KNEELING SYSTEM—The NLG hydraulic motor, which mounts on the NLG actuation system gearbox, provides power for all NLG kneeling and unkneeling operations. The motor receives power from hydraulic system No.1.

Prior to level and forward kneeling operations, the NLG gearbox must be shifted to low gear to provide the high torque necessary for the task. This is accomplished by extending the kneel pads which cause the shift clutch pilot valve to block pressure to the shift clutch located on the NLG gearbox.

NLG KNEEL PADS—The NLG is supported by kneel pads during level and forward kneeling. The kneel pads are mounted on the NLG wheel well aft bulkhead. One kneel pad is used during level kneeling and the other is used during forward kneeling. A kneeling roller, located on the bottom aft side of the NLG shock strut piston, contacts the appropriate pre-positioned kneel pad during level and forward kneeling operations. An electric actuator places the kneel pads into position during the level kneel mode. See figure 5-4 and 5-5.

NLG KNEEL PAD ACTUATOR SWITCH—A three-position, lever-lock KNEEL PAD ACTUATOR switch is located on the right side of the NLG wheel well aft bulkhead. The switch is used to extend or retract the NLG kneel pads. When the switch is held in the EXTEND position, the pads will extend to the level kneel position and the PAD NOT STOWED light will illuminate. Holding the switch to the RETRACT position retracts the pads and extinguishes the PAD NOT STOWED light.

After extending the kneel pads from the stowed position, a rig pin must be inserted in the kneel pad rig hole to assure that the pad is in the extended position. For forward kneeling, the level kneel pad must be manually extended to expose the forward kneel pad. The level

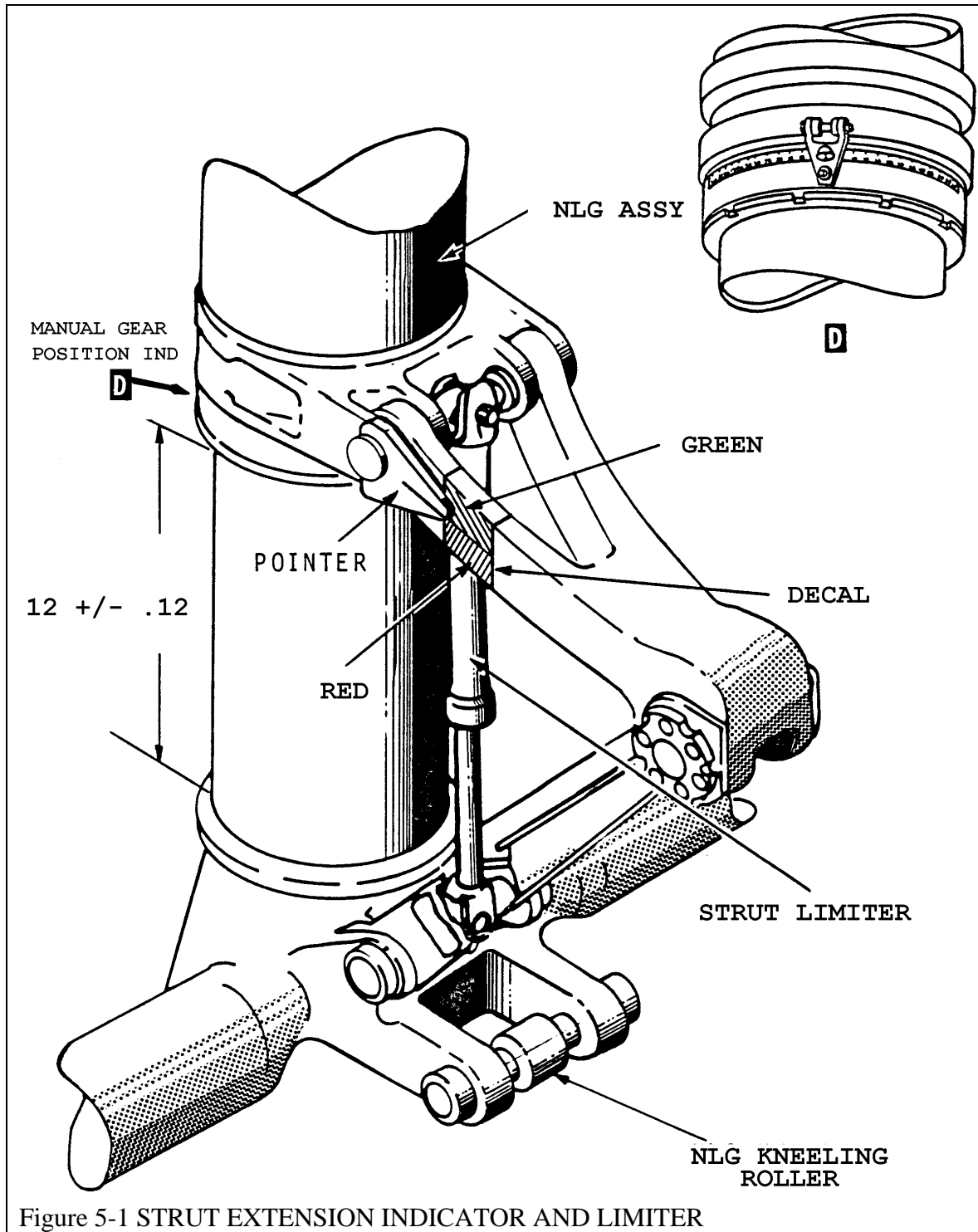
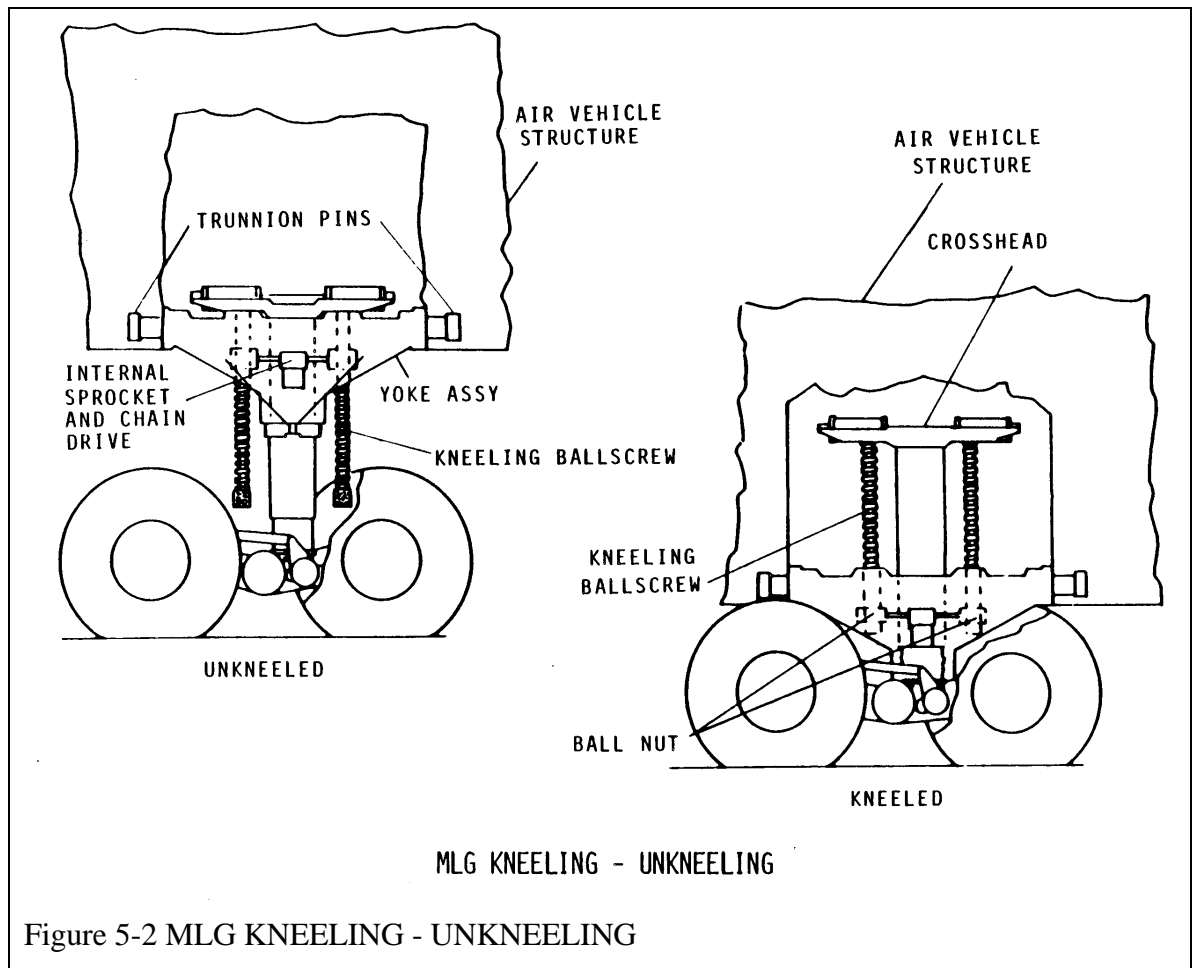
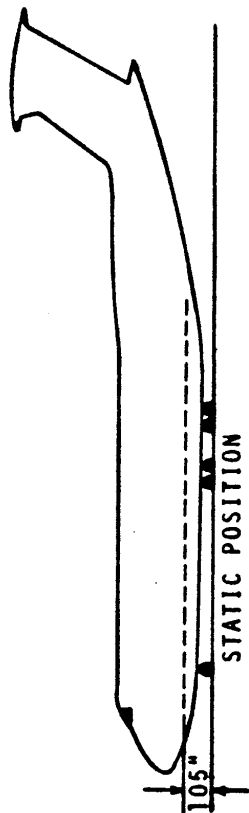

Figure 5-1 STRUT EXTENSION INDICATOR AND LIMITER



LOADING MODES

TAXI AND TAKEOFF POSITION



**FORWARD AND AFT
LOADING AVAILABLE
IN TRUCKBED OR
DRIVE IN MODES**

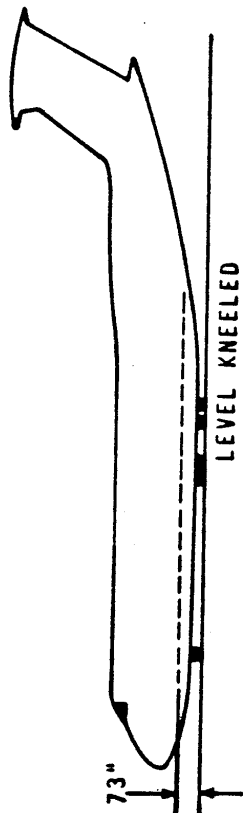

For forward kneeling, the 4-inch collars are installed on the aft gears.

**ONLY AFT LOADING
AVAILABLE IN TRUCKBED
OR DRIVE IN MODES**

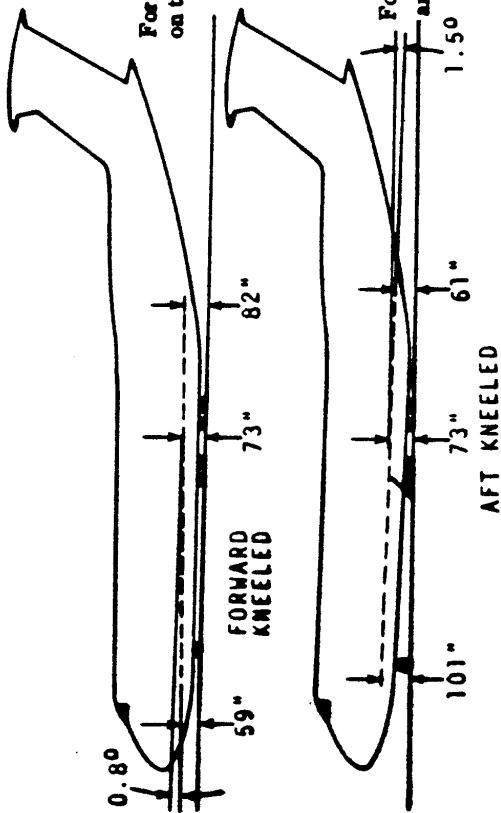

For aft kneeling, the 4-inch and the 2.75-inch collars are installed on the forward gears.

KNEELING POSITIONS AND LOADING MODES

Figure 5-3 KNEELING POSITIONS AND LOADING MODES

Kneeling Pad Positions

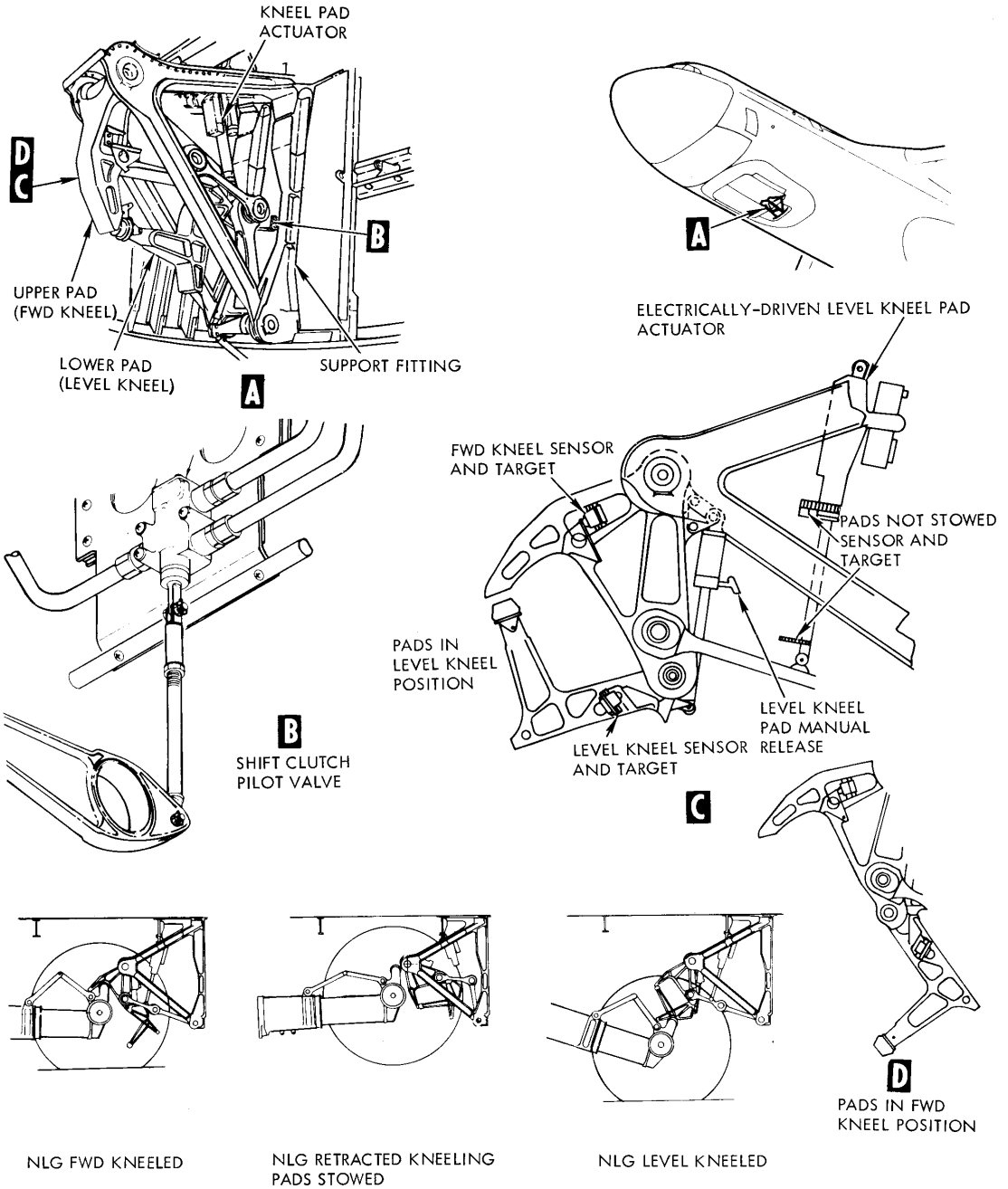
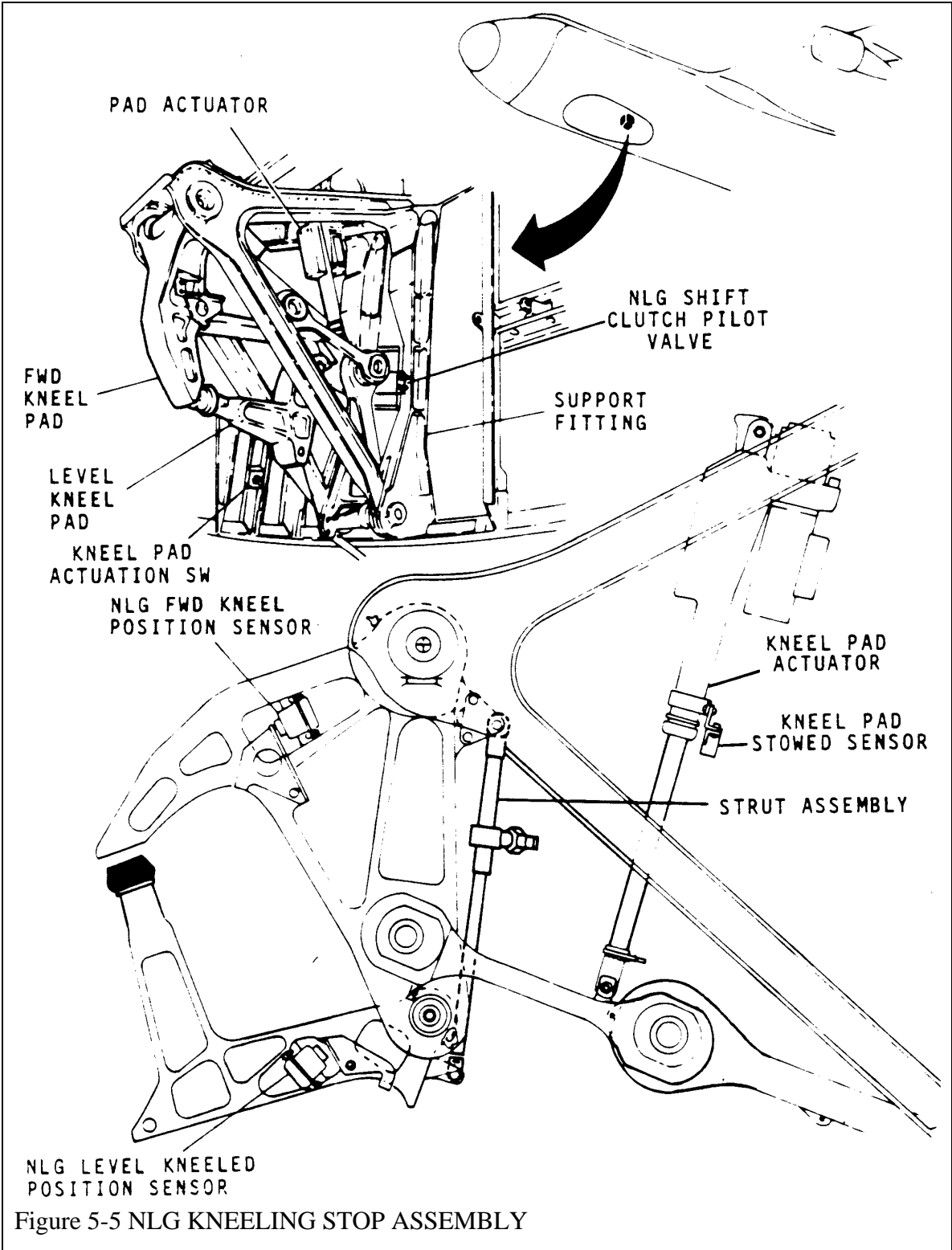

Figure 5-4 KNEEL PAD POSITIONS



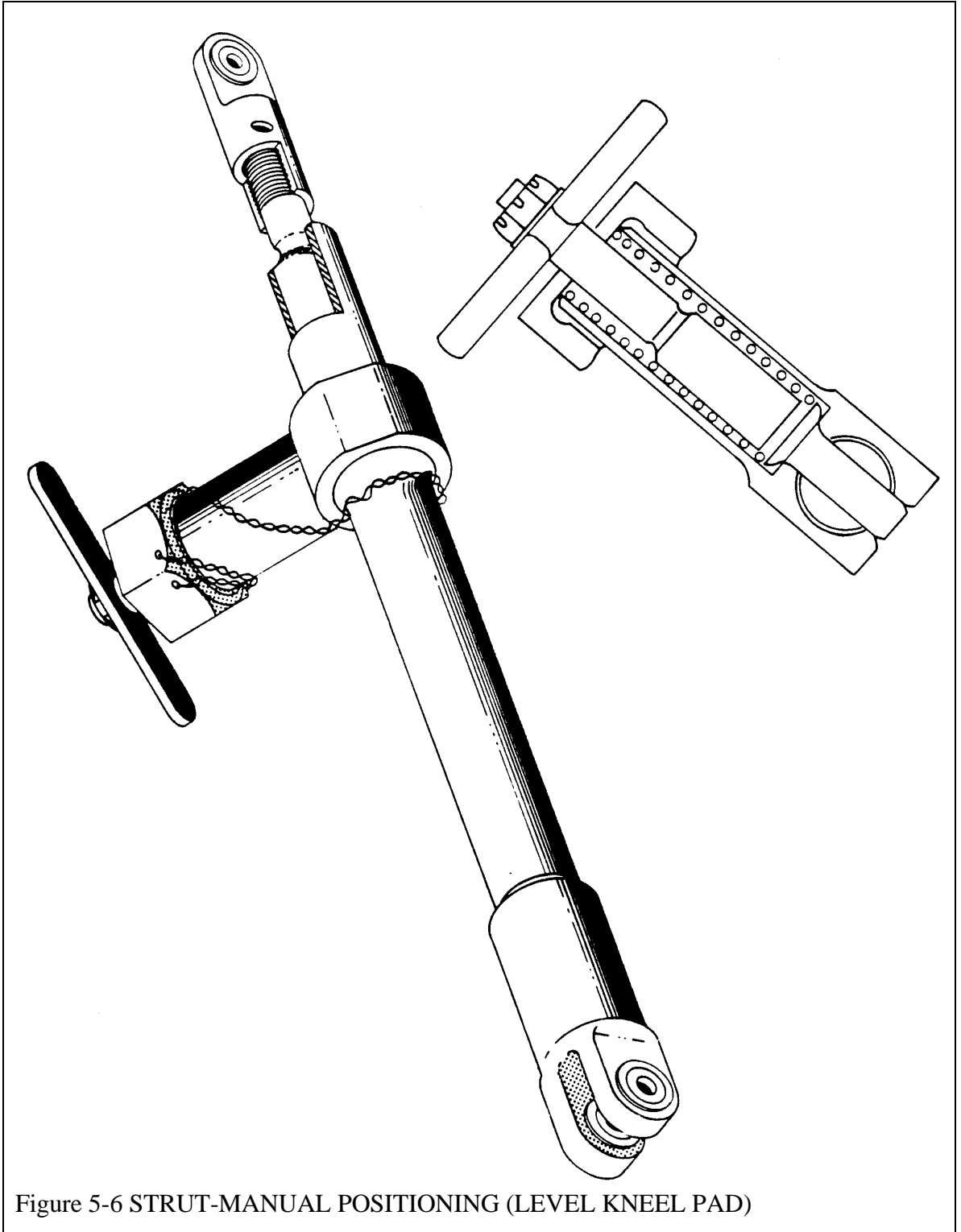

Figure 5-6 STRUT-MANUAL POSITIONING (LEVEL KNEEL PAD)

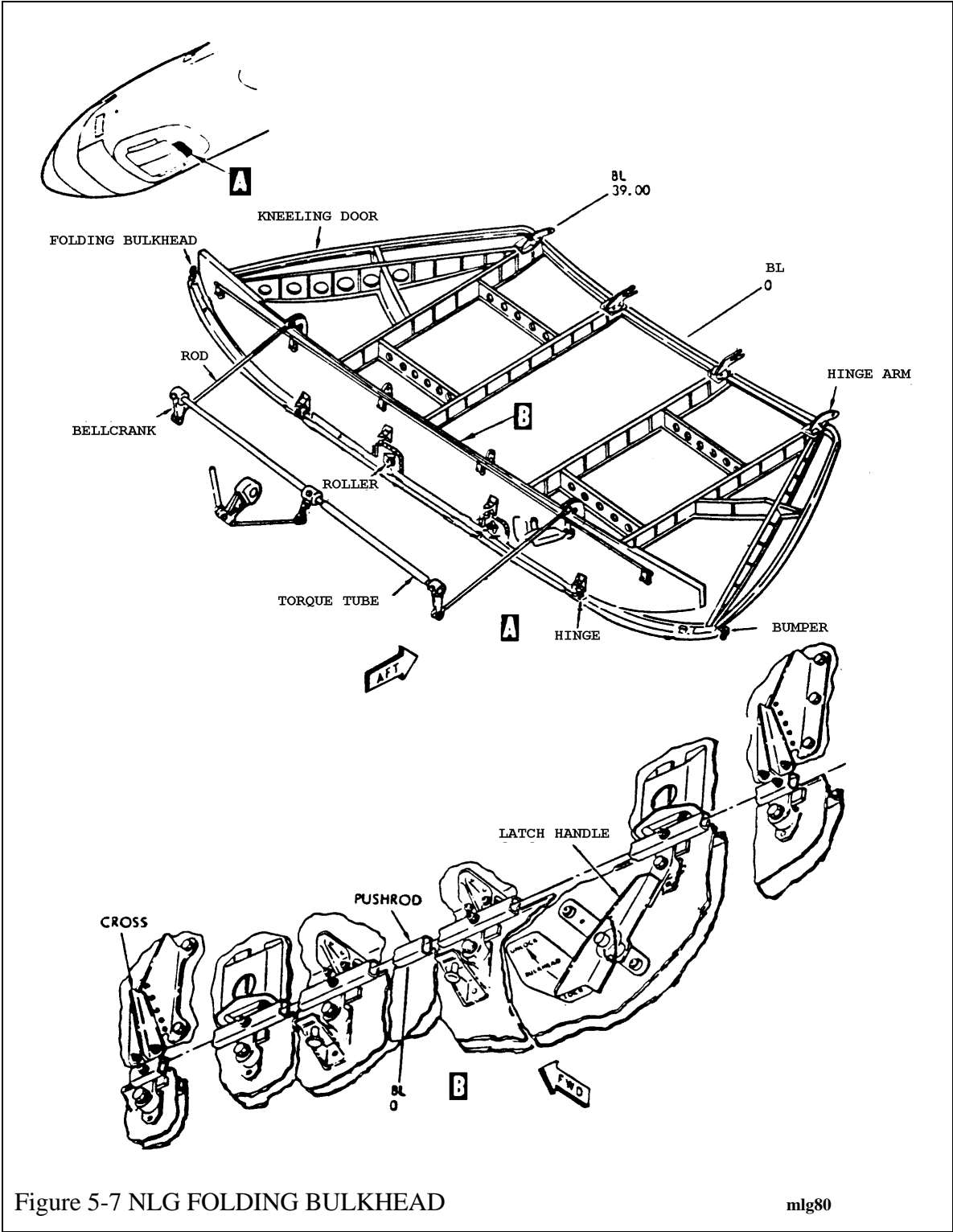

Figure 5-7 NLG FOLDING BULKHEAD

mlg80

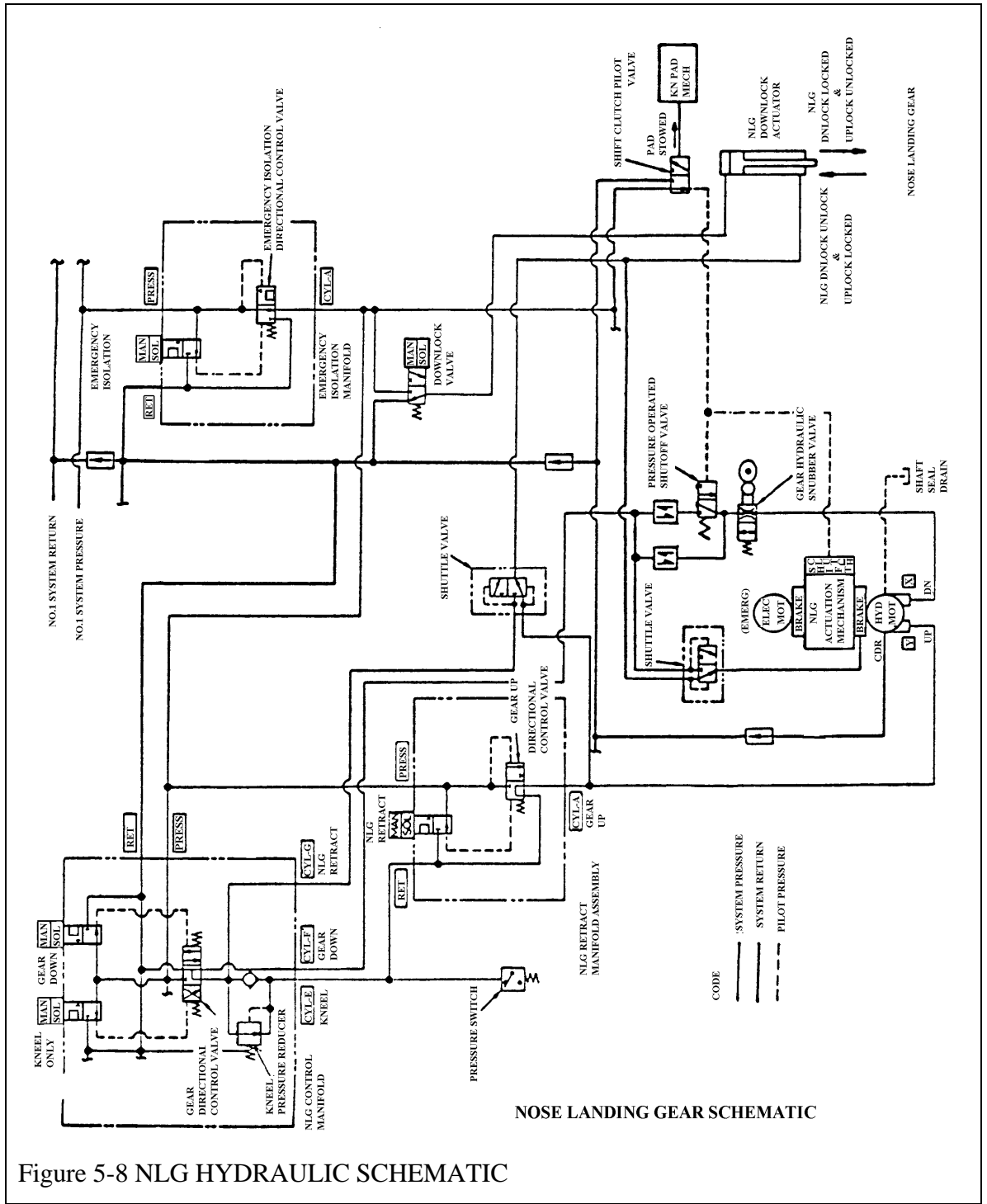

Figure 5-8 NLG HYDRAULIC SCHEMATIC

kneel pad must also be manually retracted before the pads are electrically retracted to the stowed position.

MAIN LANDING GEAR (MLG) KNEELING SYSTEM—Each MLG gear shock strut assembly is designed so that it can move vertically through a yoke assembly attached to the airframe. A crosshead assembly, carrying the positioning cylinders (AFT gears only) and rotation actuators, is formed integrally with the top portion of the shock strut. Two ballscrews, one forward and one aft of the shock strut, are attached to the crosshead assembly. The ballscrews extend through ballnuts, which are installed in the yoke. A hydraulic motor-driven gearbox mounted on the yoke drives two chains that rotate the ballnuts resulting in vertical movement of the yoke to raise or lower the aircraft. As the aircraft is lowered to a kneeled position, the bottom of the yoke comes in contact with a stop pad on the lower end of the shock strut piston or a removable collar installed in certain kneel modes. The shock cylinder continues to travel following this contact until the weight of the aircraft has been substantially relieved from the shock strut air chambers which prevents the shock strut from extending or compressing during cargo unloading. A spring-loaded brake in the kneel drive system locks the mechanism when hydraulic pressure is removed at any point in the cycle. This prevents further movement between the strut and yoke. See figure 5-2.

Power to operate the two forward kneel drive motors is furnished by hydraulic system No.4, while the two aft gear motors are driven by hydraulic system No.1.

The MLG can be kneeled individually on the ground from controls located in the left and right MLG wheel forward pods. The kneeling system can be stopped and reversed at any time during the kneeling cycle.

A hydraulic kneel control valve is located, one for each gear, in the respective landing gear control area in the cargo compartment. The valves have manual overrides to allow manual control of the kneel drive units. Hydraulic motor speed is controlled by flow regulators. The kneel position is sensed by a conventional limit switch located at the kneel limit. No asymmetry protection is provided. The operator must carefully control the kneeling operation in order to prevent structural damage.

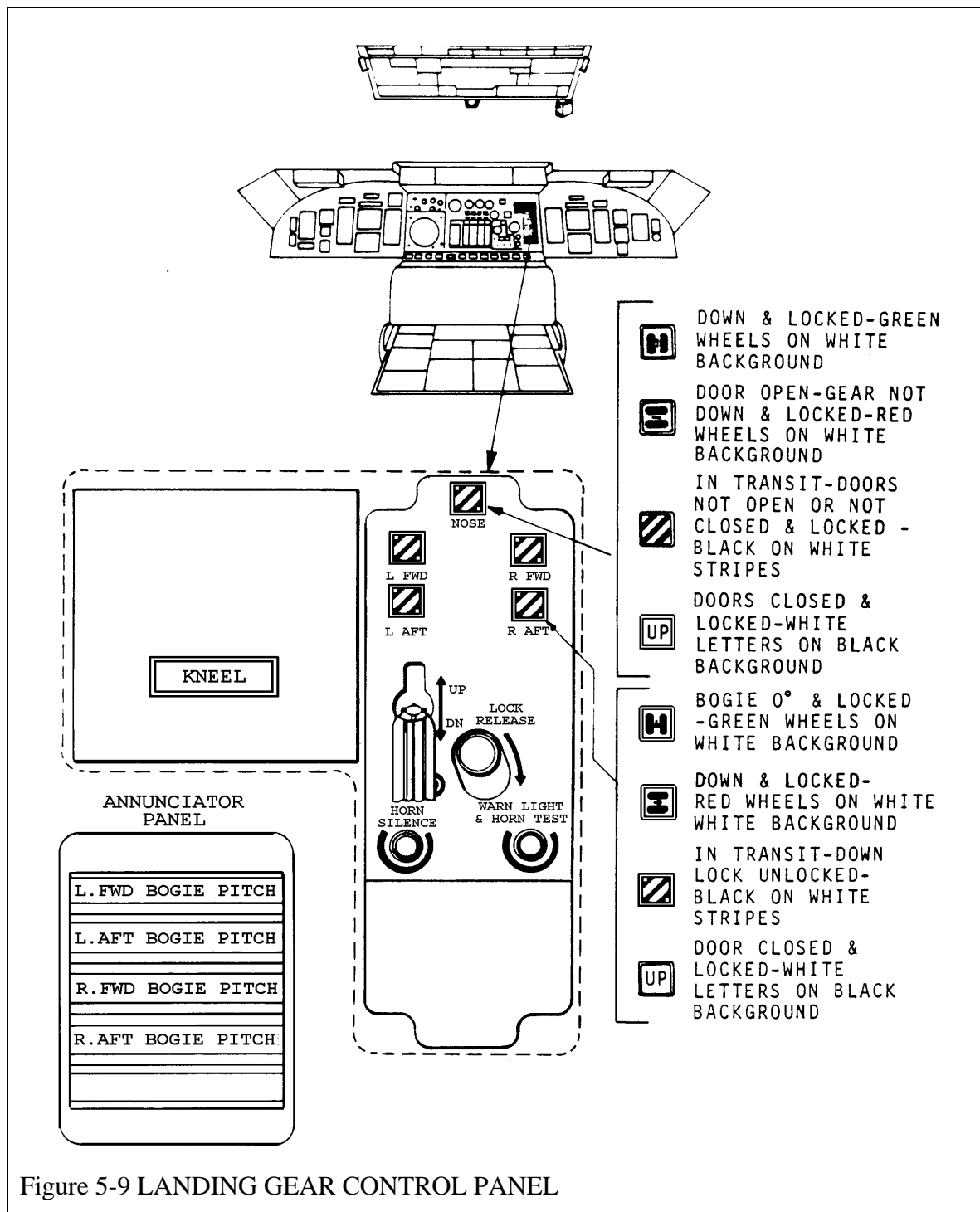

Kneeling command is originated in the flight station for all kneeling modes. In the event of a failed solenoid valve, or for inflight individual gear kneeling, manual override buttons are provided at each hydraulic kneel valve.

Hydraulic power for kneel drive motor operation is taken from the down rotate line of each related gear.

MAIN LANDING GEAR KNEELING COLLARS—Two 4-inch and two 2.75-inch kneeling collars, stowed in the stowage container located on the forward left side of the cargo compartment, are provided to

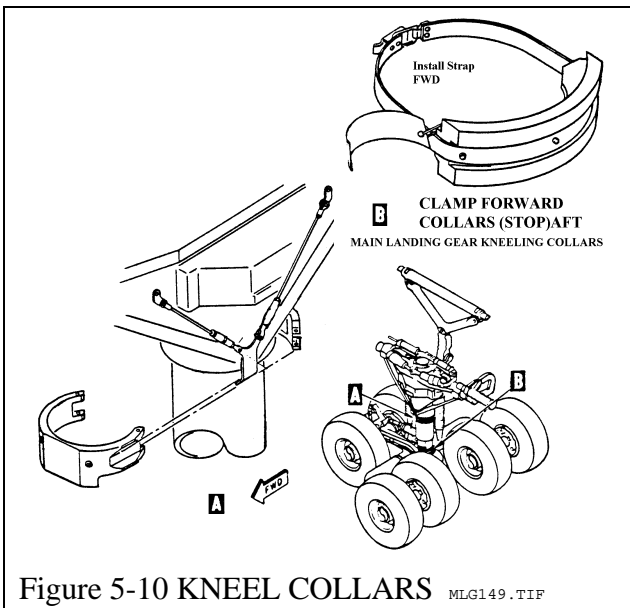

maintain the desired position of the airplane in the forward and aft kneeled position. Proper positioning of the airplane in either the aft or forward kneel mode requires selective restriction of the kneel distance of the main gears. Kneeling collars in combinations of sizes are installed around the shock strut pistons resting on the yoke stop pad. For forward kneeling, the 4-inch collars are installed on the aft gears. For aft kneeling, the 4-inch and the 2.75-inch collars are installed on the forward gears.

KNEELING INDICATION SYSTEM—The kneeling indication system consists of 12 indicator lights located on the flight engineer's Kneeling Control Panel and 1 indicator light located on the center instrument panel. See figure 5-11.

Indicator lights located on the kneeling control panel are as follows:

- ◆ An NLG NOT UNKNEELED light will illuminate if the NLG down-lock is not locked and the touchdown system indicates ground operation.
- ◆ Four NOT UNKNEELED lights, LH FWD, LH AFT, RH FWD, and RH AFT, will illuminate if their related not unkneeled switches sense that the yoke is not against the crosshead.
- ◆ A NLG KNEELED light will illuminate when the KNEEL SELECT switch is positioned to AFT, or when position to FWD or LEVEL and the NLG reaches the forward or level position.
- ◆ Four KNEELED lights, LH FWD, LH AFT, RH FWD, and RH AFT will illuminate when the related gear reaches the kneel limit.

- ◆ A PAD NOT STOWED light indicates that the NLG kneel pads are not in their proper position for a gear retraction cycle. The light will illuminate whenever the kneel pads are not in the stowed position.

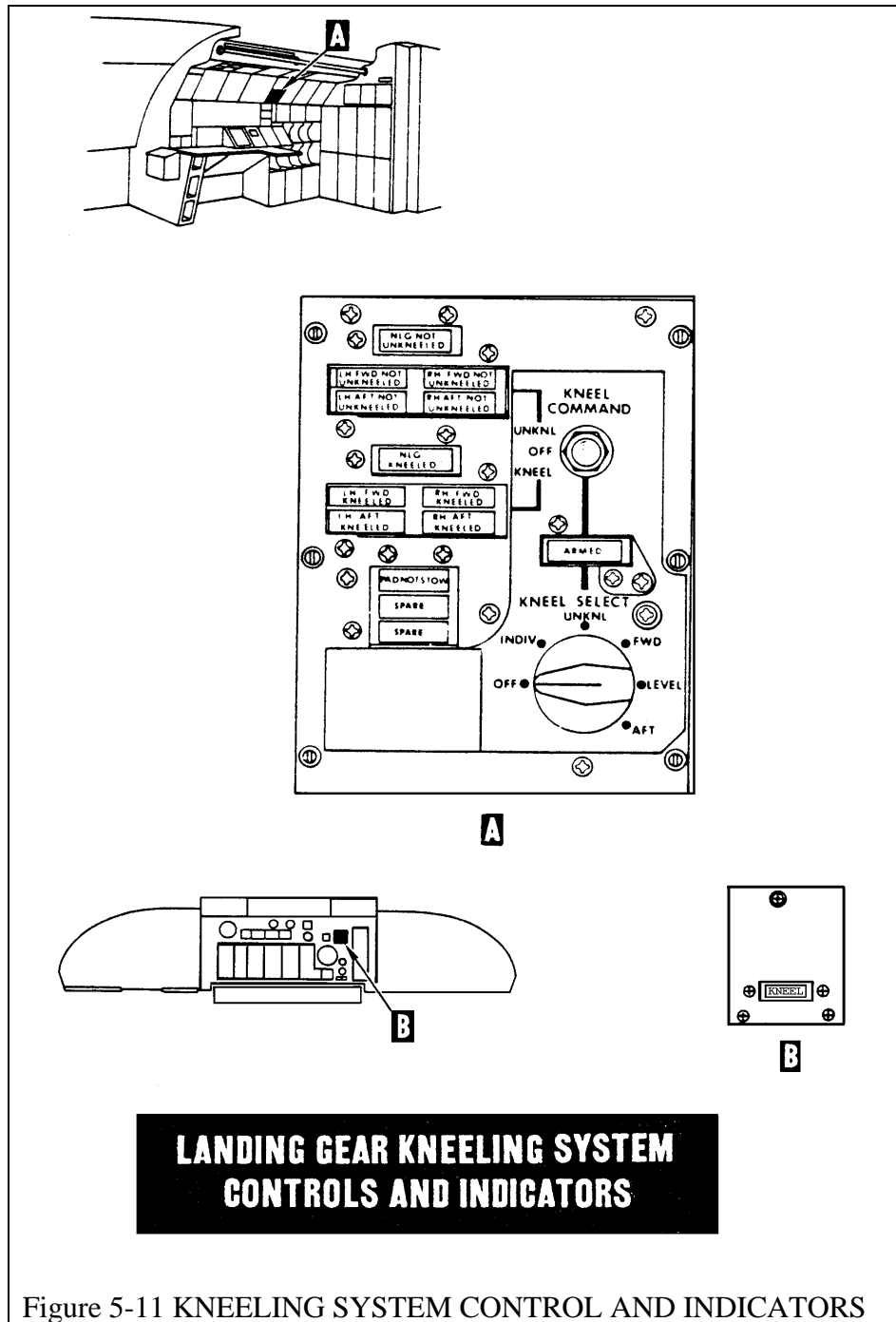

- ◆ An ARMED light will be illuminated when the KNEEL SELECT switch is positioned to INDIV, FWD, LEVEL, and AFT, provided that all MLGs are centered. The light will also illuminate if the KNEEL SELECT switch is positioned to UNKNL.

The KNEEL light located on a panel adjacent to the landing gear control handle indicates a not unkneeled condition if illuminated. The light will be illuminated if any of the gears are not unkneeled or if the NLG kneel pads are not stowed.

ELECTRICAL AND HYDRAULIC KNEELING OPERATION— See figure 5-8, 5-12, 5-13, 5-14, and 1-15. Forward, level, and aft kneeling operations are controlled from the flight engineer's kneeling control panel. The following describes the electrical and hydraulic kneeling operation after the initial conditions are established as to safety and pre-kneeling instructions. Refer to T.O. 1C-5A-2-10.

NOTE: The CENTER/CASTER select switch must be placed in the CASTER position before any kneel action may be performed. This provides a ground for the MLG kneeling caster relay.

AFT KNEEL—Before a kneeling operation is initiated, all warning lights on the Kneeling control panel and the KNEEL light on the center instrument panel must be extinguished.

Upon selecting the AFT position of the KNEEL SELECT switch, the MLG kneel caster (K56BY) relay will energize and the ARMED light will illuminate. The NLG KNEELED light will illuminate. The FWD/LEVEL relay is de-energized. The KNEEL COMMAND switch is armed.

Placing the KNEEL COMMAND switch to KNEEL energizes the kneel command relay. Power is furnished through the not-kneeled contact of the kneel limit switch at each MLG to energize the KNEEL solenoid valve.

Hydraulic pressure from the down rotate line of each main gear is furnished to the selector valve. System pressure is routed through the selector valve to a one-way restrictor, which reduces pressure for motor operation. System pressure is also routed from the selector valve to the hydraulic brake, releasing the brake. Motor speed is controlled by the one-way flow regulators. As each MLG yoke moves away from the related crosshead, a limit switch completes the circuit to illuminate a main landing gear NOT UNKNEELED light. The KNEEL light at the center instrument panel also illuminates. When each gear reaches the kneel limit (revolution counter 285 ± 4) a limit switch opens the circuit to the kneel solenoid valve. The selector valve shuts off pressure and connects both the kneel and unkneel line from the motor to return. Brake pressure is also depleted and the brake apply spring engages the brake. The related kneel limit switch also completes a circuit to illuminate the main landing gear KNEELED light. Position the KNEEL COMMAND switch to OFF. Power is removed from the kneel command relay.

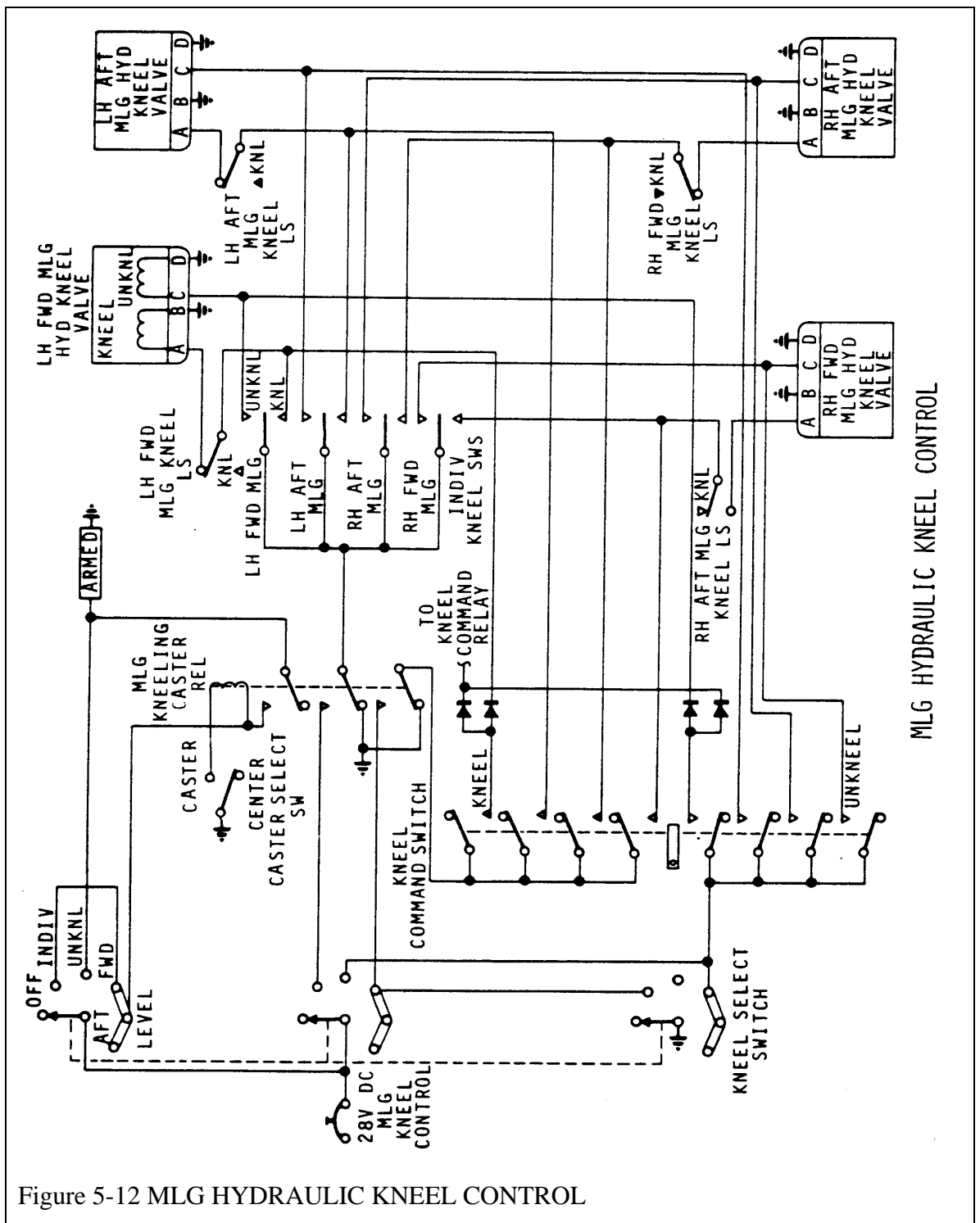
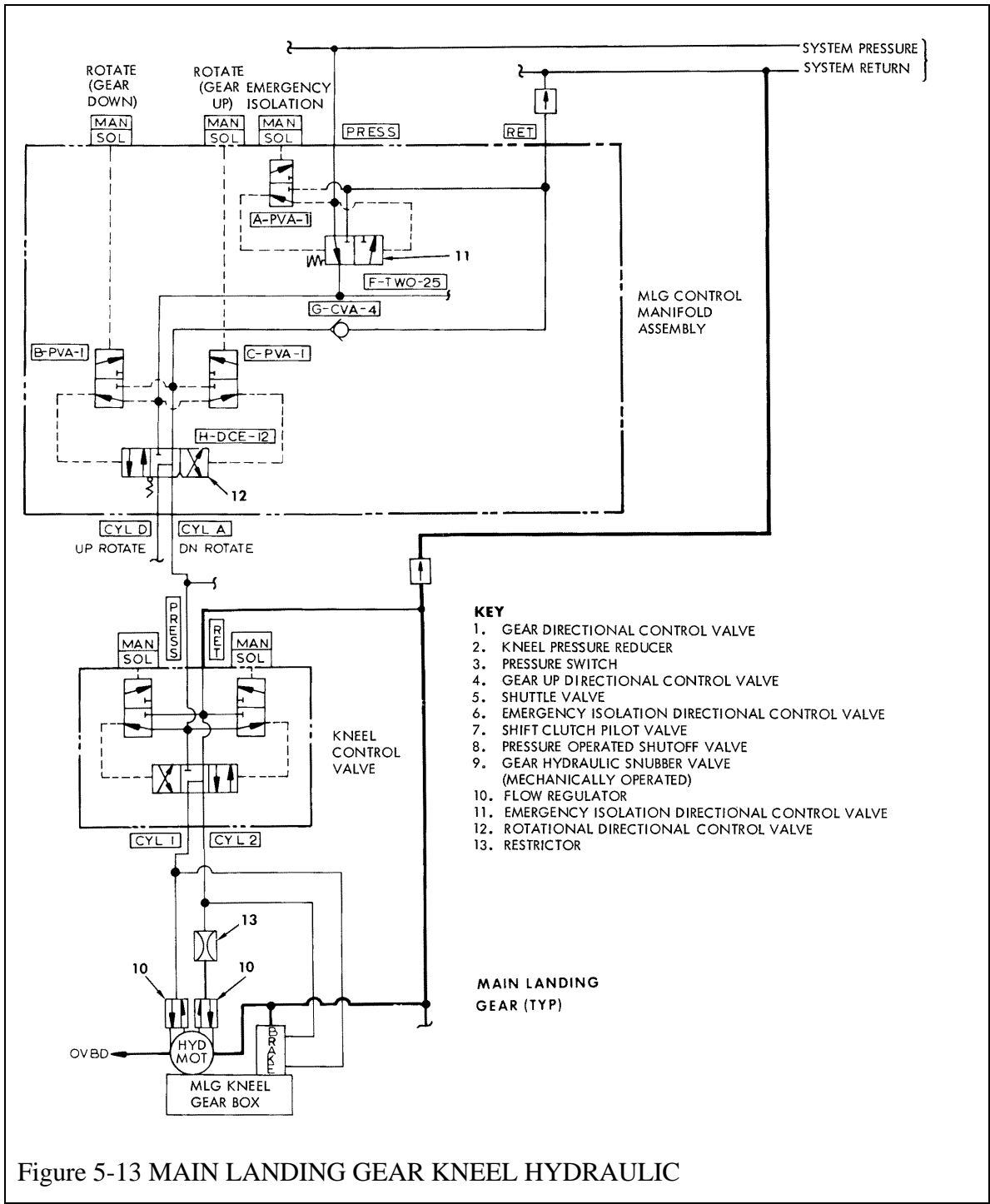
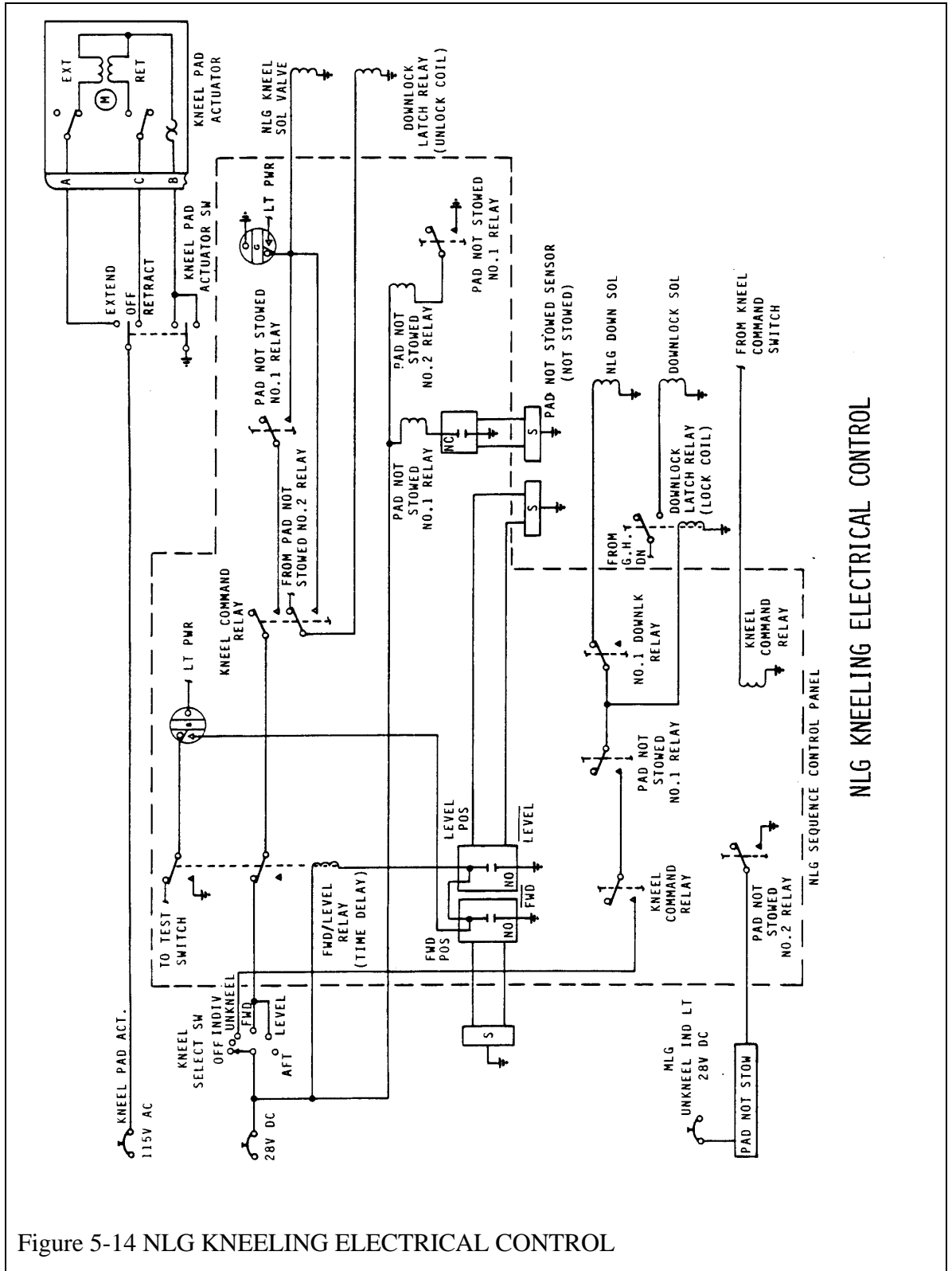

Figure 5-12 MLG HYDRAULIC KNEEL CONTROL





NLG KNEELING ELECTRICAL CONTROL

Figure 5-14 NLG KNEELING ELECTRICAL CONTROL

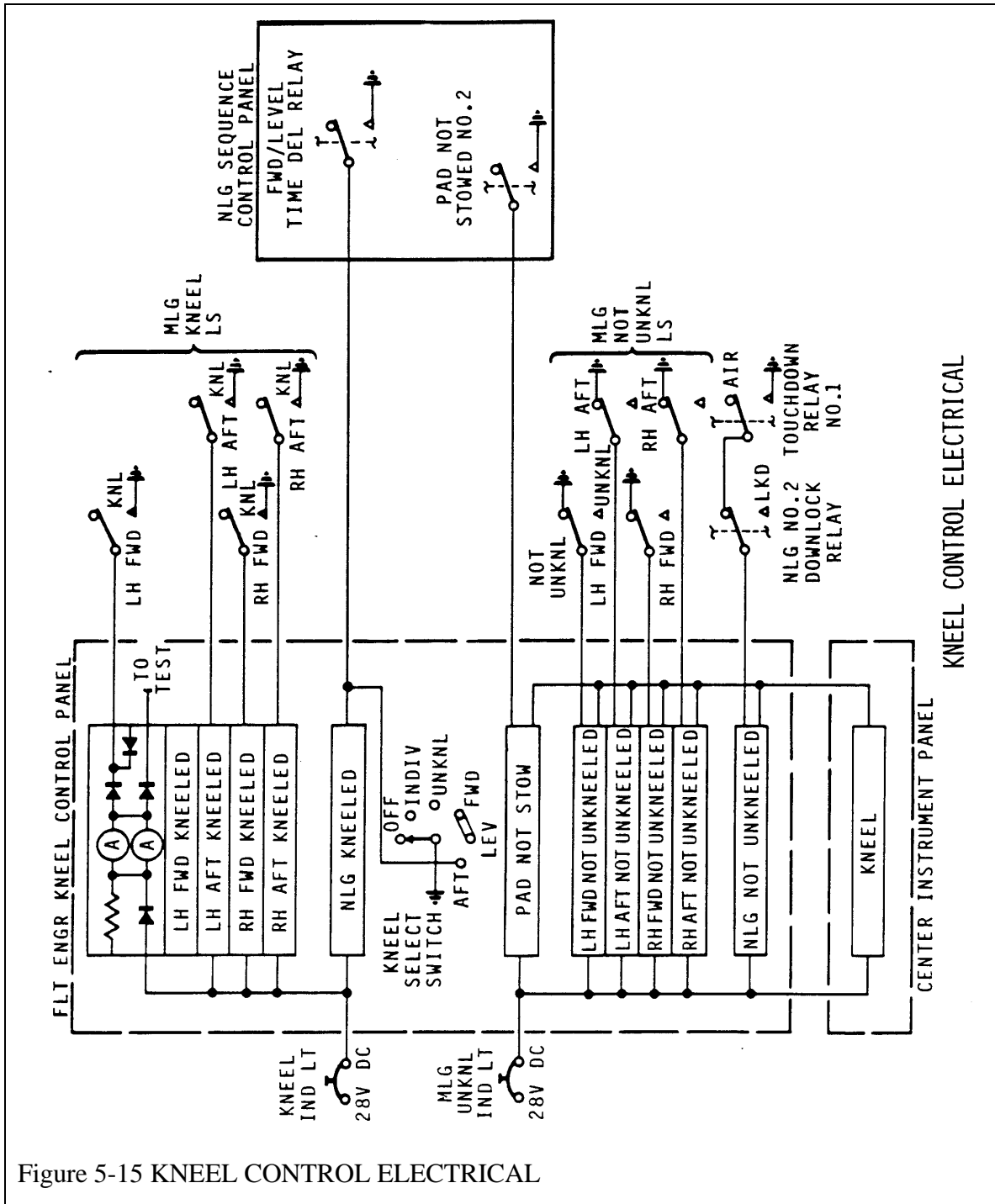

Figure 5-15 KNEEL CONTROL ELECTRICAL

LEVEL KNEEL OPERATION—The MLG electrical and hydraulic operation is the same as for the aft kneeling, MLG operation starts as soon as the KNEELING COMMAND switch is positioned to KNEEL.

NOTE: For level kneel operation the NLG kneel pads must be extended. This action causes the NLG gearbox assembly to shift to the low gear (high torque) function.

With the kneel pads extended, the PAD NOT STOW light is illuminated.

The NLG operation is as follows: Position the KNEEL SELECT switch to LEVEL arms the KNEEL COMMAND switch, energizes the kneel center relay, and illuminates the ARMED light.

Positioning the KNEEL COMMAND switch to KNEEL energizes the kneel command relay on the NLG sequence control panel.

- ◆ With the kneel command relay and the pad-not-stowed No.1 relay energized, the NLG kneel solenoid valve and the downlock latch relay are energized, unlocking and retracting the gear.
- ◆ The gear handle warning light illuminates when the NLG gear unlocks.
- ◆ The NLG NOT UNKNEELED light illuminates when the No.2 downlock relay de-energizes.
- ◆ Once the NLG reaches the level kneel position, the forward/level relay is energized, deenergizing the NLG kneel solenoid valve and the downlock latching relay. Hydraulic pressure is removed, applying the gearbox brake. The NLG rests against the level kneel stop pad.
- ◆ The NLG KNEELED light illuminates.
- ◆ Place the KNEEL COMMAND switch to OFF.

With the aircraft in the level kneel position all indicator lights located on the kneel control panel are illuminate. The KNEEL light on the center instrument panel is also illuminated.

UNKNEEL OPERATION—During unkneeling operation, the NLG and MLG will operate simultaneously. Total unkneeling time is approximately 3.5 minutes.

Upon selecting the UNKNL position of the KNEEL SELECT switch and positioning the KNEEL COMMAND switch to UNKNL, the following actions take place:

- ◆ The kneel command relay will energize, energizing the NLG downlock latch relay through the energized contacts of the pad-not-stowed No.1 relay. The downlock solenoid is energized.
- ◆ The NLG down solenoid is energized through the energized contacts of the kneel command relay, the pad-not-stowed No.1 relay, and the de-energized contacts of the No.1 downlock relay.
- ◆ Hydraulic pressure from the NLG down valve releases the brake.

- ◆ The NLG KNEELED light will extinguish.
- ◆ The NLG down solenoid will de-energize when the gear is down and locked: No.1 downlock relay is energized.
- ◆ The NLG NOT UNKNEELED light extinguishes.
- ◆ Main landing gear unkneeling operation is simultaneous with the NLG operation.
- ◆ With the KNEEL COMMAND switch positioned to UNKNL, the UNKNEEL solenoid valve related to each MLG is energized.
- ◆ Hydraulic pressure is directed to the MLG hydraulic motor and brake assemblies.
- ◆ The MLG kneeling brake is released.
- ◆ The motor operates at a speed which is controlled by a pressure regulator.
- ◆ As the gear moves out of the kneeled position, the related KNEELED light extinguishes.
- ◆ When the MLG yoke contacts the crosshead, the hydraulic motor stalls out.
- ◆ The related gear NOT UNKNEELED light will extinguish.
- ◆ Hold the KNEEL COMMAND switch for 5 seconds after the last gear NOT UNKNEELED light extinguishes.
- ◆ MLG counters should read 000 ± 1.0 .
- ◆ Releasing the KNEEL COMMAND switch de-energizes the UNKNEEL solenoid valve and removes pressure from the hydraulic motor and brake; brake is applied.
- ◆ Stow the kneel pads.
- ◆ Place the KNEEL SELECTOR switch to OFF.
- ◆ All indicator lights on the kneel control panel are extinguished. The KNEEL light on the center instrument panel is extinguished.
- ◆ The gear handle warning light was extinguished when the NLG downlock was engaged.

Chapter Six —BRAKE SYSTEM

GENERAL

There are 24 hydraulically operated brakes on the main landing gear, 6 brakes per gear. The brakes are controlled in pairs so that braking action will be symmetrical with respect to the strut centerline. Braking action is initiated by operation of the brake metering pilot valve through the rudder pedals resulting in operation of the main metering valve, in the brake and skid control manifold, to supply brake pressure proportional to metered pressure. Each pair of brakes is controlled by a separate main metering valve in the brake and skid control manifold. The braking action is monitored by the anti-skid system which decreases brake pressure when a skid condition exists.

Pressurized fluid to actuate the brakes may be supplied from the No.4 hydraulic system (normal) or the No.1 hydraulic system (alternate) or from a 400-cubic inch accumulator pressurized by system No.4. Brake system selection is provided by a switch on the center instrument panel. Normal brake pressure is supplied from the forward gear hydraulic manifold and alternate brake pressure is supplied from the aft gear hydraulic manifold.

Each of the four main landing gear systems is controlled by an electro-hydraulic anti-skid control valve which consists of three two-stage metering valves and two shuttle valves. Each pair of brakes within a single main gear brake system is controlled by one of the two-stage metering valves which is controlled by metered pressure from the respective pilot metering valve and the electronic skid control circuitry. The pilot metering valves are connected by mechanical linkages to the pilot's and copilot's brake pedals. When the brake pedals are depressed, pilot-metered pressure is applied to the two-stage metering valves, which meter pressure from the landing gear-down rotate line to the brake. The two-stage metering valves, in response to the pilot-metered pressure and the electronic skid control circuitry, modulate the pressure applied directly to the brakes. In the event that hydraulic pressure is not available from system No.1 or system No.4, the fully charged accumulator will provide three full brake applications. This emergency pressure is applied by the pilot metering valves through the parking brake selector valve directly to the brakes.

The brake system incorporates a parking brake function, which utilizes pressure from the normal or alternate system or from the emergency accumulator. To set the brakes, the brake pedals are depressed, the parking brake handle is pulled, and the pedals released. This latches the brake pedals in the depressed position to keep pressure on the brakes.

BRAKE SYSTEM CONTROLS AND INDICATIONS—The BRAKE SUP selector switch, located on the pilots' center instrument panel is provided to select the normal, alternate, or emergency supply systems for brake operations. In the NORM position, the hydraulic system No.4 solenoid-operated shutoff valve is open and the emergency and the No.1 system shutoff valves are closed. In the ALT position, the hydraulic system No.1

solenoid-operated shutoff valve is open and the emergency and No.4 system shutoff valves are closed. In the EMER position, the No.1 and No.4 hydraulic systems shutoff valves are closed, and the emergency system shutoff valve is open. Anti-skid protection is provided only in the NORM and ALT positions. The BRAKE SUP selector switch receives 28-volt DC power from the isolated DC bus and the main DC bus No.1.

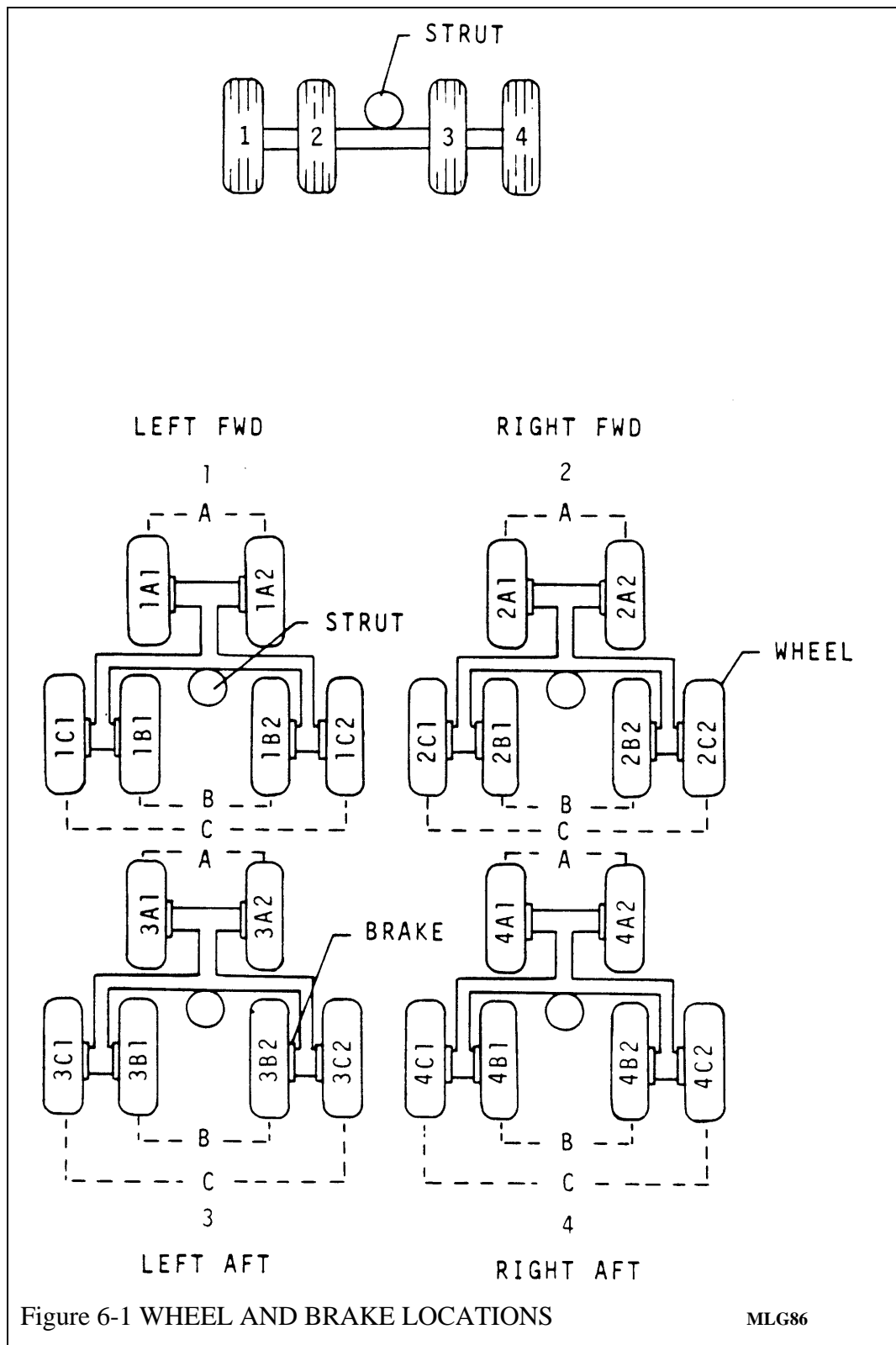

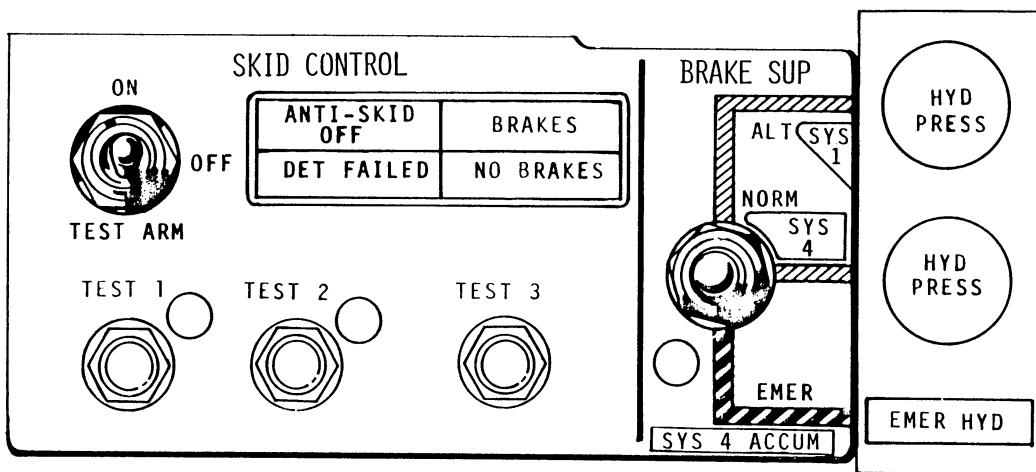
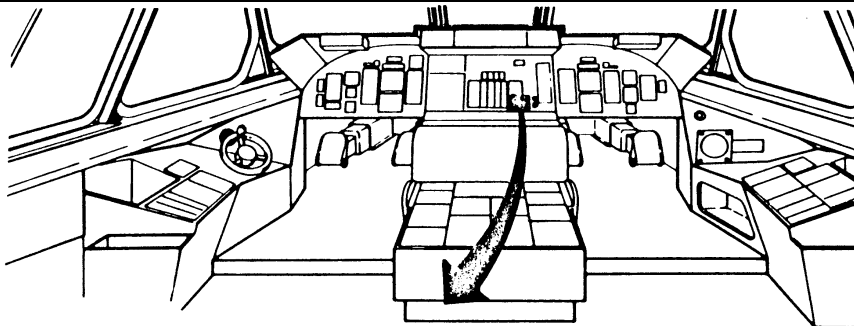

BRAKE AND SKID CONTROL INDICATION

Figure 6-2 BRAKE AND SKID CONTROL INDICATION

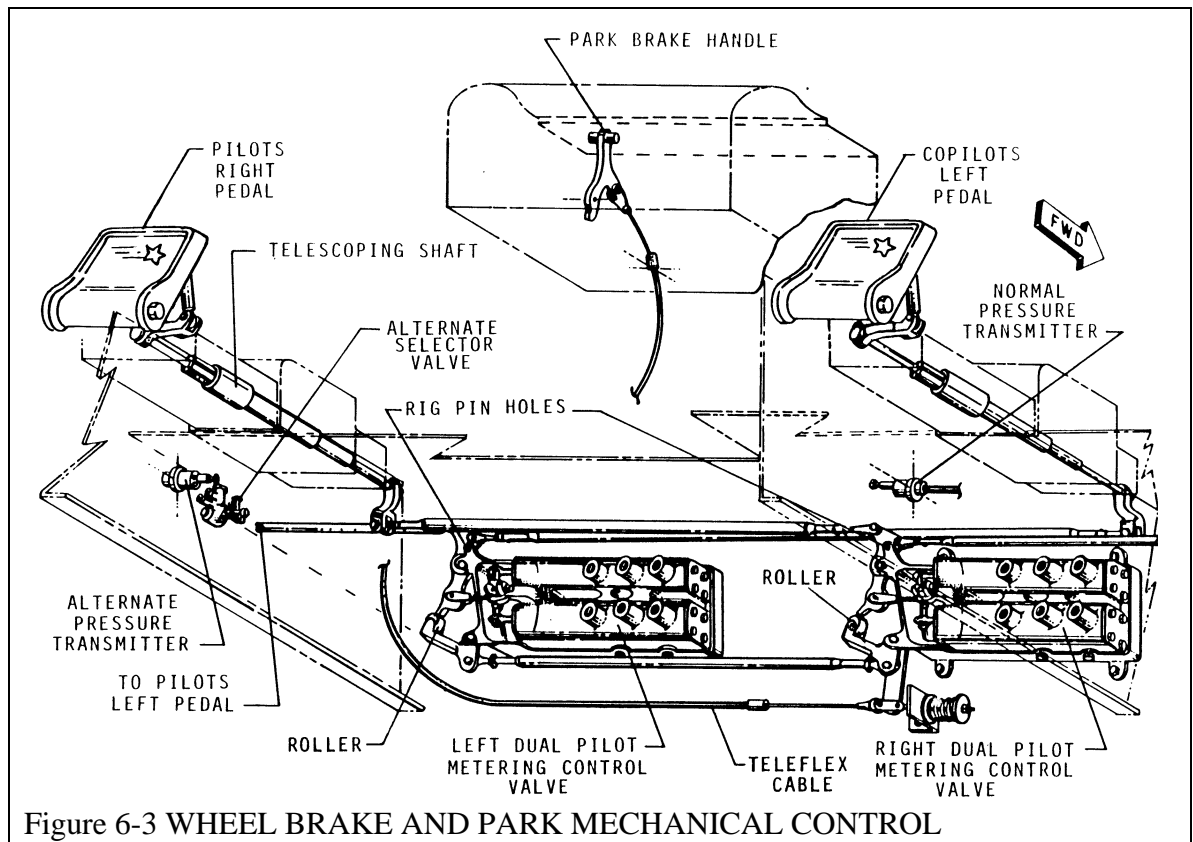

Figure 6-3 WHEEL BRAKE AND PARK MECHANICAL CONTROL

PARKING BRAKE HANDLE—The brakes can be locked for parking purposes by using the brake handle located on the control pedestal. The parking brakes are set by fully depressing the brake pedals, pulling the brake handle, and then releasing the brake pedals. When setting the parking brakes, depress pedals firmly. The pedals should have a positive resistance and should not spring back after the parking pawl is engaged. The parking brakes are released by fully depressing either set of brake pedals. See figure 6-3.

BRAKE PRESSURE INDICATORS—Two hydraulic brake pressure indicators, located adjacent to the BRAKE SUP selector switch on the pilots' center instrument panel, indicate pressure of the normal or alternate hydraulic system, whichever is selected for brake operation. The indicators are graduated from 0 to 4,000 PSI in increments of 250 PSI. The indicators receive signals from pressure transmitters installed in the supply lines downstream of the No.1 and No.4 hydraulic shutoff valves. The indicators receive 26-volt AC power from the AC instrument buses No.1 and No.4. See figure 6-2.

EMERGENCY HYDRAULIC BRAKE PRESSURE LIGHT—The EMER HYD brake pressure light located adjacent to the BRAKE SUP switch on the pilots' center instrument panel will come on when pressure from the emergency accumulator is providing a minimum of 1,300 PSI, and the BRAKE SUP selector switch is in the EMER position. The light receives a signal from the pressure switch installed in the supply line down-

stream of the emergency system shutoff valve. The light receives 28-volt DC power from the isolated DC bus. See figure 6-2.

ANTI-SKID SYSTEM

A fail-safe anti-skid control system is installed to provide maximum braking efficiency for all types of runway conditions and to prevent locking of the braked wheels in the event excessive brake pressure is applied by the pilot during ground operation above approximately 15 knots. The anti-skid system is fully modulated with solid state, modular control circuitry. Each module receives skid detector signals from two wheels and independently controls the same pair of brakes through an anti-skid metering valve. When a skid detector senses an impending wheel skid a signal is sent through the skid control box to the appropriate anti-skid metering valve. The anti-skid metering valve then directs an amount of metered pressure to opposite end of the main metering valve spool causing a reduction in pressure applied to the pair of brakes. A failure of a modular skid control circuit will cause the release of braking pressure to the associated pair of brakes. Skid control malfunction of any pair of brakes will cause a DET FAILED light on the center instrument panel to come on. The anti-skid system incorporates complete built-in test features for ground and in-flight functional testing. The locked wheel protection circuit tests and anti-skid brake tests are performed at the anti-skid control panel on the center instrument panel and also at the anti-skid control box. The deceleration circuit test and the line replaceable unit fault isolation test are performed with the BITE at the skid control box located in the cargo compartment close to the left main gear wheel well.

ANTI-SKID SWITCH—The anti-skid switch is located on the pilots' center instrument panel. The ON position of the switch is effective only if the BRAKE SUP selector switch is in the NORM or ALT position. When this condition is satisfied, the ON position arms the 28-volt DC anti-skid circuits. The TEST ARM position provides a means of testing the anti-skid system for proper operation. Placing the switch in the TEST ARM or OFF position with no braking pressure applied will cause a NO BRAKES light adjacent to the switch to come on. Depressing the brake pedals will cause the NO BRAKES light to go off and a BRAKE light to come on. See figure 6-2.

Each of these two lights is connected in series with the twelve pressure switches in the brake lines, which supply the twelve pairs of brakes. If either light fails to come on, a malfunction of either a brake control valve (or valves) or a pressure switch (or switches) is indicated. Fault isolation to a pair of wheels may be achieved by using the BITE check at the anti-skid control box. When the switch is placed in OFF position, the anti-skid function of the brake system is inoperative.

The anti-skid switch receives 28-volts DC power from the isolated DC bus and the main DC bus No.1 and 26-volts AC power from the AC instrument bus No.1. The BRAKES and NO BRAKES lights both receive 28-volt DC power from the main DC bus No.1.

ANTI-SKID TEST BUTTONS—Three anti-skid test buttons, located on the pilots' center instrument panel are used in conjunction with the TEST ARM position of the anti-skid switch to test the locked wheel protection portion of the anti-skid system when the

brakes are applied. The TEST ARM position of the anti-skid switch provides a 400-Hz AC test signal, which simulates a wheel spin-up signal. With this spin-up signal available, depressing the TEST 1 or TEST 2 button sends the spin-up signal to one of the two control channels in each anti-skid control card. Since the other channel in each card is sensing a locked-wheel condition, the NO BRAKES light should come on. Depressing both TEST 1 and TEST 2 buttons at the same time sends a spin-up signal to both control channels in each anti-skid control card. In this condition, anti-skid brake application is properly indicated by the BRAKES light. The TEST 3 button is provided to test the over-voltage protection device in the anti-skid circuit. Proper operation of the over-voltage device is checked by placing the anti-skid switch to TEST ARM, depressing the TEST 3 button and observing the ANTI-SKID OFF and BRAKES lights on. See figure 6-2.

ANTI-SKID OFF LIGHT—An ANTI-SKID OFF light, located on the pilots' center instrument panel comes on under any of the following conditions:

- ◆ Anti-skid switch is OFF.
- ◆ BRAKE SUP switch is in EMERG.
- ◆ Loss of the two electrical power sources supplying the anti-skid control box.
- ◆ ANTI-SKID switch is in TEST ARM and the TEST 3 push-button is depressed.
- ◆ ANTI-SKID switch is ON and an over-voltage condition exists.

The light receives 28-volts DC power from the isolated DC bus.

ANTI-SKID DETECTOR FAILED LIGHT—The anti-skid DET FAILED light, located on the pilots' center instrument panel comes on when a skid control malfunction has occurred in one or more pairs of brakes which causes one or more pairs of wheels to free-wheel for more than 3 seconds. The DET FAILED light will not come on in flight. The light receives 28-volt DC power from the isolated DC bus.

DESCRIPTION AND LEADING PARTICULARS OF THE BRAKE AND SKID CONTROL SYSTEM

There are 24 hydraulically operated brakes on the main landing gear, 6 brakes per gear. The brakes are controlled in pairs so that braking action will be symmetrical with respect to the strut centerline. Braking action is initiated by operation of the brake metering pilot valve through the rudder pedals resulting in operation of the main metering valve, in the brake and skid control manifold, to supply brake pressure proportional to metered pressure. Each pair of brakes is controlled by a separate main metering valve in the brake and skid control manifold. The braking action is monitored by the anti-skid system which decreases brake pressure when a skid condition exists.

Each main metering valve receives normal pilot-metered pressure and system supply pressure from hydraulic system No.4. In the event hydraulic system No.4 is not available, hydraulic system No.1 may be selected as an alternate. The alternate hydraulic system has the same skid control protection as the normal brake control. An accumulator is provided in the hydraulic brake system to furnish emergency hydraulic supply in the event system No.1 and No.4 pressures are not available. The emergency system bypasses the skid control system. See figures 6-4 and 6-5.

BRAKE SYSTEM OPERATION (NORMAL)—The normal brake system utilizes hydraulic system No.4. Setting the brake supply switch on the center instrument panel to the NORM position initiates the following actions:

- ◆ The brake control solenoid of the alternate brake control valve manifold is energized to block pressure from hydraulic system No.1.
- ◆ On AF66-8303 through AF70-467, the emergency brake pressure solenoid of the park brake and wheel anti-rotation manifold is energized to isolate the park brake accumulator. On AF83-1285 and up, the park brake valve is energized to isolate the parking brake accumulator.
- ◆ The brake control solenoid of the normal brake control valve manifold is de-energized to apply hydraulic system No.4 pressure to the following:
 - Four way selector valve to pre-position the selector valve to direct metered pressure to the brake and skid control manifold (BM) port.
 - Park brake and wheel anti-rotation manifold shuttle valve. The shuttle valve directs brake pressure to the brake metering pilot control valves. Manual operation of the brake actuates the brake metering pilot valves to direct the pilot-metered pressure through the linear directional control valve and on to the brake and skid control manifolds.
 - In the brake and skid control manifold the pressure operated linear directional control valve is positioned to allow No.4 hydraulic system pressure to be applied to the main metering valves. The pilot-metered normal pressure is directed to the skid control valve and to the main metering valve. Pilot-metered normal pressure also pre-positions the park brake selector valve. Pressure is then directed through the hydraulic fuses to pairs of brakes.

ALTERNATE BRAKE OPERATION—The alternate brake system utilizes hydraulic system No.1. Setting the brake supply switch to the ALT position initiates the following actions:

- ◆ The brake control solenoid of the normal brake control valve manifold is energized to block pressure from hydraulic system No.4.
- ◆ On AF66-8303 through AF70-467, the emergency brake pressure solenoid of the park brake and wheel anti-rotation manifold is energized to isolate the parking brake accumulator. On AF83-1285 and up, the park brake valve is energized to isolate the parking brake accumulator.
- ◆ The brake control solenoid of the alternate brake control valve manifold is de-energized to apply hydraulic system No.1 pressure to the brake metering pilot valves. Manual operation of the brake pedals actuates the dual pilot-metering brake control valves to direct the pilot-metered pressure directly to the brake and skid control manifolds.
- ◆ In the brake and skid control manifold the pressure operated linear directional control valve is positioned to allow No.1 hydraulic system pressure to be applied to the main metering valves. The pilot-metered alternate pressure is directed to the skid control valve and to the main metering valve. Pilot-metered alternate pressure also pre-positions the park brake selector valve. Pressure is then directed through the hydraulic fuses to pairs of brakes.

EMERGENCY BRAKE OPERATIONS—The emergency brake system receives pressure from the emergency and park brake accumulator. Setting the brake supply switch to the EMERG position initiates the following actions:

- ◆ The brake control solenoids of both the normal and alternate brake control valve manifolds are energized to block pressure from both hydraulic systems.
- ◆ On AF66-8303 through AF-467, the emergency brake pressure solenoid of the park brake and wheel anti-rotation manifold is de-energized to apply accumulator pressure to the internal shuttle valve. On AF83-1285 and up, the brake valve is de-energized to apply accumulator pressure to a separate shuttle valve. The shuttle valve directs the accumulator pressure to the brake metering pilot valves.
- ◆ Manual operation of the brake pedals actuates the dual pilot-metering brake control valves to direct the pilot-metered pressure through the linear directional control valve. The four-way selector valve is pre-positioned by an internal spring to direct pressure to the wheel anti-rotation shuttle valve.
- ◆ From the shuttle valve the pressure is directed to the brake and skid control manifold. The internal selector valve is positioned by the accumulator-metered pressure to direct pressure through the hydraulic fuses to the brake assemblies. The accumulator pressure bypasses the skid control system. An indicator light reading EMERG HYD informs the flight crew that emergency brake operation is limited.

PARKING BRAKES OPERATIONS—The emergency and parking brake accumulator supplies hydraulic pressure for the parking brakes when the hydraulic and electrical systems are shut down. To apply parking brakes, set the brake supply selector switch to the EMER position. Depress the brake pedals and pull the parking brake handle. All brake control solenoids are de-energized. The emergency and parking brake control valve is closed, directing accumulator pressure to the brake system the same as for emergency brake operation. When electrical power is restored to the airplane, the EMERG HYD indicating light will alert the crew to the emergency position of the brake supply selector switch.

PARKING BRAKE—The parking brake is a mechanical linkage which locks the pilot's or copilot's brake pedals in the brakes applied position. The parking brake handle is located on the center console, forward and left of the throttle quadrant. The parking brake handle is attached by a cable to a latch mechanism. The latch mechanism holds the two dual brake metering pilot valves in the open position. To operate the parking brake when the engines are shut down, it is necessary to move the brake control panel switch to the EMER position. Depressing the brake pedals will release the park brake handle after the brakes have been set.

BRAKE MECHANICAL CONTROL—The rudder control pedals also function as brake pedals. The right or left landing gear brakes are applied by *toe pressure* on either the pilot's or copilot's rudder pedals. A series of pushrods and torque tubes transfer rudder pedal *toe pressure* to a dual pilot brake metering control valve. The pilot's left and right brake pedals are connected by linkage to the copilot's left and right brake pedals. The left brake pedals are connected to the left brake control valve, the right brake pedals are connected to the right brake control valve. Thus, depressing one of the left brake pedals operates the 12 brakes on the left side of the airplane, depressing one of the right brake pedals operates the 12 brakes on the right side of the airplane. Full brake pedal travel is approximately 25°.

BRAKE HYDRAULIC CONTROL SYSTEM—The main gear brakes are operated by either of two independent hydraulic power systems or an emergency hydraulic accumulator system. Hydraulic power system No.4 provides normal brake pressure, system No.1 provides alternate brake pressure. The accumulator also provides pressure for application of the park brake. The brake hydraulic control system consists of the following components:

- ◆ Brake system control panel.
- ◆ Two brake selector valves (normal and alternate).
- ◆ Park brake and wheel anti-rotation manifold.
- ◆ Two dual pilot brake metering control valves.
- ◆ Anti-wheel rotation shuttle valve. (On AF66-8303 through AF70-467).

MLG WHEEL BRAKE HYDRAULIC SCHEMATIC (SHEET 1 OF 2)

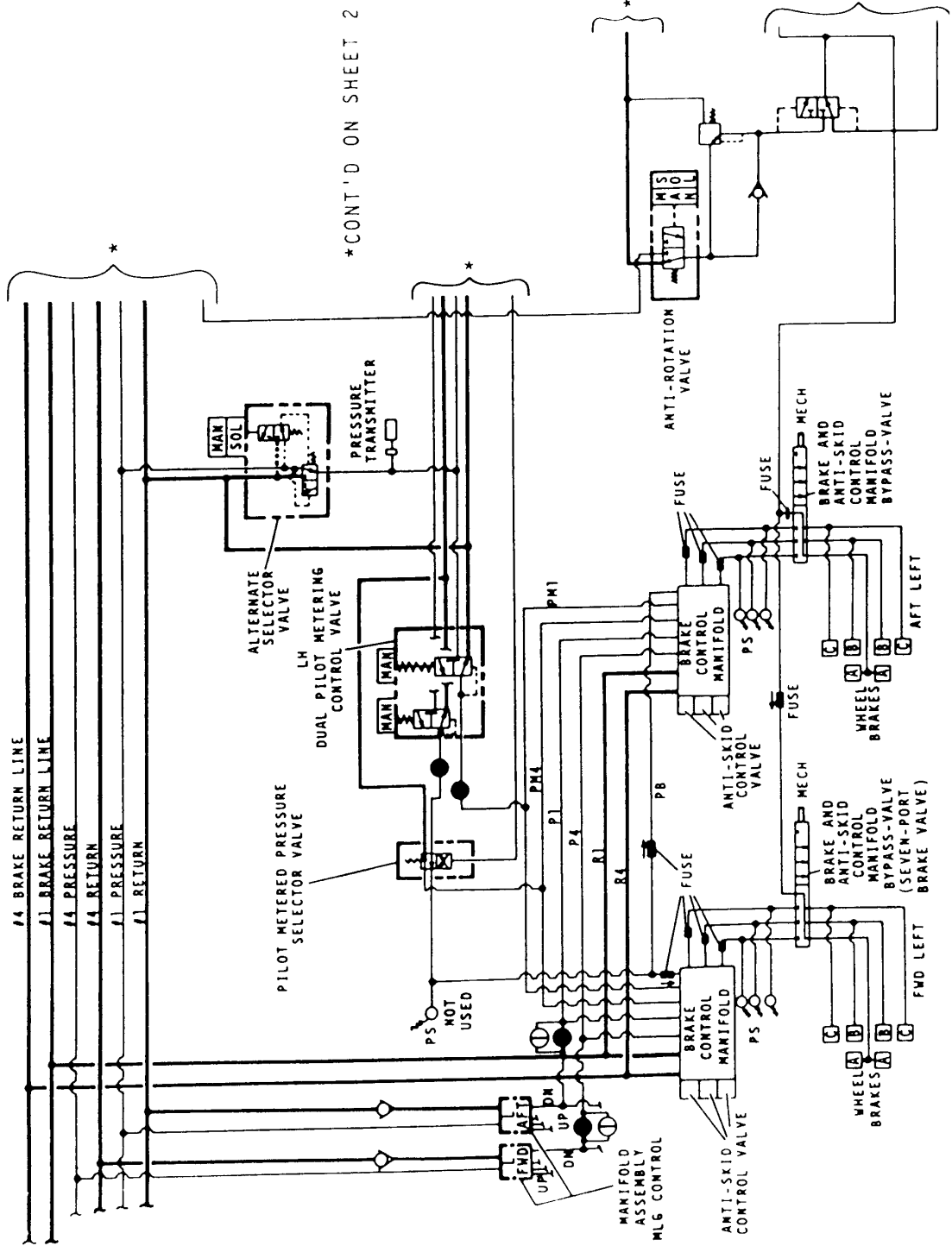

MLG WHEEL BRAKE HYDRAULIC SCHEMATIC (SHEET 2 OF 2)

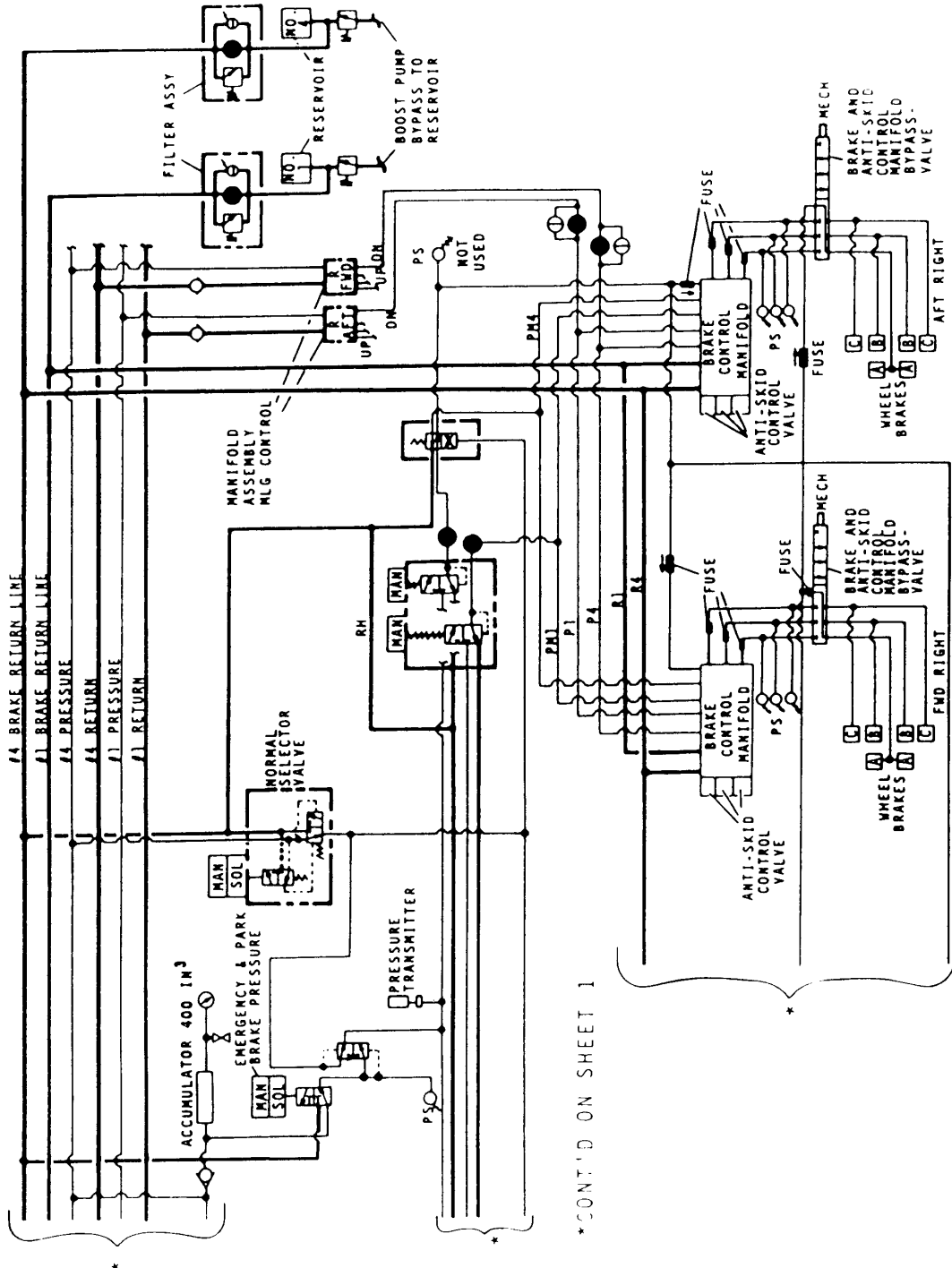

Figure 6-5 MLG WHEEL BRAKE HYDRAULIC (SH 2 OF 2)

- ◆ Park brake valve. (On AF83-1285 and up.)
- ◆ Four brake and skid control manifolds.
- ◆ Sixteen hydraulic fluid quantity limiters (fuses).
- ◆ Hydraulic pressure accumulator.
- ◆ Two hydraulic pressure transmitters.
- ◆ Two hydraulic pressure indicators.

The skid control system is a part of the hydraulic brake system and consists of three basic components:

- ◆ Control module.
- ◆ Twelve skid control valves.
- ◆ Twenty-four wheel speed detectors.

The skid control system senses an impending skid condition and prevents a continued skid. The skid control system is available to both the normal and alternate brake hydraulic systems. Emergency brake operation does not include the skid control system.

BRAKE SYSTEM CONTROL PANEL—The brake system control panel is located on the center instrument panel. The following switches, lights, and gages are located on the panel:

- ◆ **BRAKE SUP (BRAKE SUPPLY) SWITCH**—This switch has three positions to provide for selection of the NORM (normal), ALT (alternate), or EMER (emergency) brake hydraulic system.
- ◆ **NORMAL AND ALTERNATE BRAKE SYSTEM PRESSURE GAGES**—These gages indicate the pressure to the dual pilot metering valves.
- ◆ **EMERG AND ALTERNATE BRAKE PRESSURE GAGES**—These gages indicate the pressure to the dual pilot metering valves.
- ◆ **EMERG HYD LIGHT**—The light indicates that pressure is available to the emergency brake system.
- ◆ **SKID CONTROL SWITCH**—This is a three position switch used to control the skid control system. The switch positions are ON, OFF, and TEST ARM.
- ◆ **SKID CONTROL INDICATING LIGHTS**—The lights indicate normal or faulty conditions during skid control operation. The light captions are ANTI-SKID OFF, DET FAILED, BRAKES and NO BRAKES.
- ◆ **TEST SWITCHES**—The skid control system has three built-in test circuits. The TEST 1 and TEST 2 are used to test the locked wheel protection portion of the anti-skid system. The TEST 3 is used to apply 28 volts onto the over voltage supply pickup relay.

BRAKE CONTROL VALVE MANIFOLD—The brake control valve manifolds direct hydraulic pressure from the normal (No.4) and alternate (No.1) hydraulic systems to

the brake system. The alternate selector valve is located under the flight deck floor, while the normal selector valve is adjacent to the emergency and park brake accumulator. The valves are open when de-energized. Each valve is operated by a solenoid having a manual override. The BRAKE-SUP switch on the brake system control panel electrically operates the valve's solenoid. The NORM switch position energizes the valve in the No.1 hydraulic line to the closed position. This allows the valve in the No.4 hydraulic system to supply hydraulic pressure to the brake system. The ALT switch position energizes the valve in the No.4 hydraulic line to the closed position. This allows the valve in the No.1 hydraulic system to supply hydraulic pressure to the brake system. The emergency brake pressure valve is energized closed when the brake supply selector switch is in the NORM or ALT position. The EMER switch position energizes both valves to the closed position, allowing emergency brake operation from the brake accumulator.

PARKING BRAKE AND WHEEL ANTI-ROTATION MANIFOLD (AF66-8303 through AF70-467)—The parking brake and wheel anti-rotation manifold performs the following functions:

NOTE: The wheel anti-rotation functions of the manifold are not used. The PRESS A port and CYL A port of the manifold are plugged with AN814 plugs.

- ◆ The control and flow of hydraulic fluid for the normal brake system from the NORM selector valve to the two pilot metering valves.
- ◆ The control and flow of hydraulic fluid for the emergency/park brake accumulator to the two pilot metering valves.

The manifold is located on the side wall of the cargo area adjacent to the right forward wheel well. The manifold contains a shuttle valve, which directs either NORM system brake pressure or EMER accumulator brake pressure to the dual pilot-metering brake control valves. An emergency brake pressure manual solenoid operated valve within the manifold ports accumulator pressure to the dual pilot metering brake control valves. The emergency brake pressure valve is energized closed when electrical power is available and the brake supply selector switch is in the NORM or ALT position. In the closed position the valve provides for pressurizing the accumulator. Placing the brake supply selector switch to its EMER position de-energizes the emergency brake pressure valve, thus directing brake accumulator pressure to the dual pilot-metering brake control valve.

EMERGENCY AND PARKING BRAKE PRESSURE VALVE (AF83-1285 and up)—The parking brake valve is located on the side wall of the cargo area adjacent to the right forward wheel well. The valve is energized closed when electric power is available and the brake supply selector switch is in the NORM or ALT position. When closed, normal system hydraulic pressure is directed through a shuttle valve to dual pilot metering brake control valves. Placing the brake supply selector switch to EMER position de-energizes the valve. When the valve is de-energized, emergency brake accumulator pressure is directed through a shuttle valve to brake control valves.

The anti-rotation system is separate from the parking brake manifold. The PRESS A port and CYL A port of the parking brake manifold are plugged with AN814 plugs.

The anti-rotation system is pressurized through a normally closed three-way selector valve and a pressure reducer. The selector valve is energized open at liftoff to port system No.4 pressure to the pressure reducer and thus reduces pressure (to approximately 150 PSI) to the brakes through the seven-port valve. There is a hydraulic fuse located ahead of the seven-port valve. The electrical control circuit is controlled by the gear handle. An electrical signal is sent from the gear handle, when the handle is in the UP position, to the anti-rotation solenoid, when the anti-rotation pressure acts to stop the rotating wheels, the No.2 anti-rotation spin-up relay is de-energized to interrupt the power to the anti-rotation valve. The No.1 anti-rotation relay is de-energized at the same time to allow the gear to retract.

PILOT-METERING BRAKE VALVE—The two valves are mechanically actuated hydraulic valves used to meter hydraulic brake control pressure to the brake and skid control manifolds. The valves meter pressure, which controls the amount of working pressure available to the brake assemblies. The working pressure applied to the brakes is directly proportional to the outlet pressure of the pilot-metering control valve. The actual metering of the working brake pressure takes place within the brake and skid control manifolds. The brake pressure applied to the brake assemblies is supplied from the down rotate lines of the four MLG control manifolds. During normal operation, No.4 hydraulic system pressure from the left forward MLG control manifold is directed to the twelve left brake assemblies. No.4 hydraulic system pressure from the right forward MLG control manifold is directed to the twelve right brake assemblies. During alternate system operation, No.1 hydraulic system pressure is supplied to the left and right brake assemblies from the left and right aft MLG control manifolds. The two pilot metering control valves are located forward and below the rudder pedals. They are mechanically actuated by either the pilot's or copilot's brake pedals. The brake control valves provide for brake pedal feel with an internal spring.

EMERGENCY AND PARK BRAKE ACCUMULATOR—The emergency and park brake accumulator provides a reserve supply of hydraulic pressure for emergency braking and for the parking brakes. The accumulator is located on the cargo compartment wall adjacent to the right hand forward MLG. It is installed upstream of the park brake and wheel anti-rotation manifold, off the No.4 hydraulic power system. A check valve is installed between the accumulator and the pressure line to retain accumulator pressure when the system is shut down. The capacity of the accumulator is 400 cubic inches. A direct reading pressure gage and a high-pressure air valve are provided for servicing the accumulator. A pressure switch installed on the park brake and wheel anti-rotation manifold is actuated (1300 PSIG or greater) when accumulator pressure is applied to the system. The pressure switch operates the EMERG HYD light on the brake supply panel.

BRAKE SYSTEM HYDRAULIC PRESSURE TRANSMITTERS AND INDICATORS—A pressure transmitter and indicator are installed in the line of each brake hydraulic power system. The pressure transmitters are located under the flight deck floor in the pressure lines to the pilot metering brake control valves. The brake pressure indicators are located on the brake supply panel. The indicators provide a reading of pressure available to the pilot from either the normal, alternate or emergency brake hydraulic systems.

DESCRIPTION AND LEADING PARTICULARS OF THE BRAKE

The brake assembly is the multiple disc-type. Alternate discs called rotors are keyed to the wheel and rotate with it. The remaining discs are stationary, and are keyed through a splined torque tube to three lugs on the strut axle. Braking action is accomplished by pressing the rotating and non-rotating disc together.

BRAKE HEAT SINK—The brake heat sink consists of four rotating discs (rotors) and five stationary discs (stators). Each of the two end stators consists of two discs whereas the other three stators consist of two discs with a thin spacer between each pair.

The stators are prevented from rotating by splines on the torque tubes which engage slots in the I.D. of the stators. Similar slots in the O.D. of the rotors engage splines in the wheel so that the rotors rotate with the wheel. Both the rotors and the stators are free to move axially along their respective splines. Braking action occurs when the rotating rotors and stator plates are clamped together by moving the first stator toward the torque tube back plate. The heat sink disks are all composed of structural carbon material.

BRAKE PISTON HOUSING—The brake piston housing is bolted to the torque tube by eleven bolts. Eight hydraulically actuated pistons attached to the housing generate the clamping action by moving out of the housing against the first stator. Each piston capsule is individually replaceable without removing the brake assembly from the axle. The piston capsules consist of the piston assembly, a piston insulator, a piston sleeve, a cylinder cap, and hydraulic packings. To compensate for brake disc wear at each brake application, an automatic adjustment is incorporated in each piston capsule. The cylinder cap is threaded into the housing. Drilled passageways in the housing connect the piston cavities. There are two bleed ports in each housing so that a bleed port will be on top at both left and right installations. Two wear pin assemblies attached to the piston housing provide a means to visually check the wear condition of the discs.

BRAKE AUTOMATIC ADJUSTMENT—Automatic adjustment for brake wear is an integral part of each of the eight piston capsules. When the brakes are released, spring force in the piston assembly overcomes the system backpressure on the piston assembly to pull the piston assembly away from the first stator. Return of the piston assembly is restricted to a specific distance by an expansion tube, a plunger, and a spring. Brake actuation pressure is sufficient to push the plunger to expand the tube so that as the brake discs wear, the pistons extend further. The return pressure, however, is not great enough to overcome the friction between the friction sleeve and the plunger so that the piston assembly is returned only a uniform built-in distance.

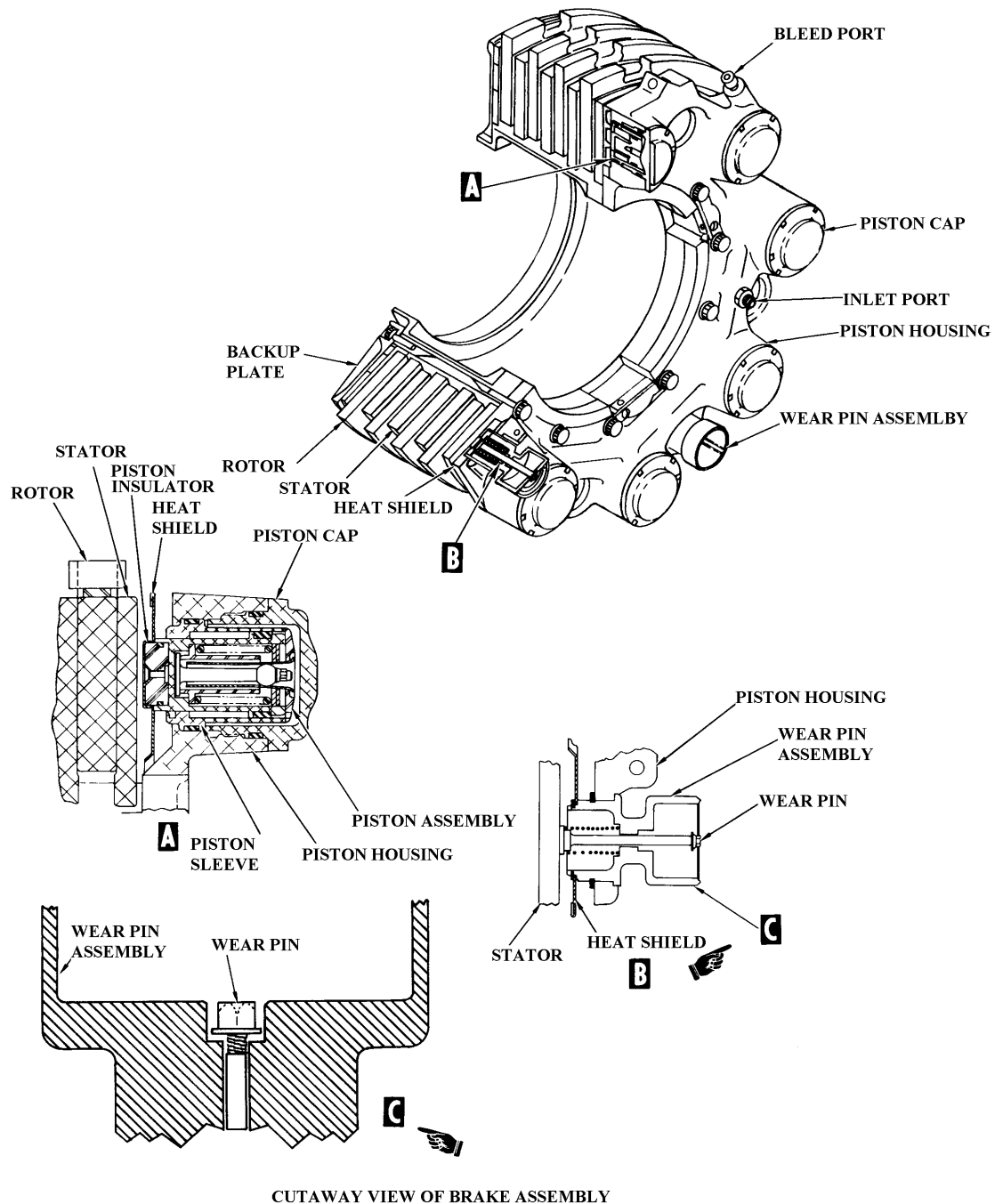

Figure 6-6 BRAKE ASSEMBLY

LINEAR DIRECTIONAL CONTROL VALVES—There are two four-way linear directional control valves, designated as left and right. The linear directional control valves are installed in the left and right brake hydraulic systems downstream from the pilot metering brake control valves. They direct pressure to either the parking brake port (PB) or normal port pressure (BM) of the forward and aft brake and skid control manifolds. When the normal system (No.4) is selected and normal system pressure is available, the selector valve is hydraulically actuated to port pressure to the NORMAL, port (pressure BM) of the forward and aft brake and skid control manifold. When the normal brake control valve is energized or hydraulic system No.4 is depressurized, the actuation pressure is vented to return, allowing the selector valve to shift, porting metered emergency and parking brake accumulator pressure to the PARK BRAKE port (PB) of the forward and aft brake and skid control manifold. The linear directional control valves are located on the side wall of the cargo area adjacent to the right forward wheel well.

FLUID QUANTITY MEASURING FUSES—Hydraulic fuses are used to close hydraulic lines downstream of the brake and skid control manifolds if a hydraulic line or component should rupture or break. There is one fuse for each pair of brake assemblies, one for each anti-skid manifold, and one located ahead of the seven-port valve, making a total of 20 fuses in the system. The fuses are located on the side wall of the cargo area below the brake and skid manifolds. In the event hydraulic fluid passes through the fuse in a volume in excess of the fuse capacity, the fuse will shut off the line. The fuse automatically resets itself when pressure is removed. A spring loaded lever on the fuse permits bypassing the metering section of the fuse during brake bleeding.

WHEEL ANTI-ROTATION OPERATION—The wheel anti-rotation system automatically applies reduced brake pressure to the brakes to stop wheel rotation after takeoff. In order for the wheel anti-rotation system to operate, the landing gear handle must be raised and a wheel spin-up must be detected. The following actions occur:

- ◆ The wheel anti-rotation valve is energized to direct No.4 hydraulic system pressure to a pressure reducer. This valve contains a manual override button which may be used to manually accomplish this purpose.
- ◆ The pressure reducer sends the reduced pressure (approximately 225 PSIG¹) to each of the seven-port valves.
- ◆ The seven-port brake valve is mechanically positioned by shock strut extension to port the reduced pressure to the brake assemblies.

The electrical control circuit is controlled by the gear handle. An electrical signal is sent from the gear handle, when the gear handle is in the UP position, to the anti-rotation solenoid. When the anti-rotation pressure acts to stop the rotating wheels, the No.2 anti-rotation spin-up relay is de-energized to interrupt the power to the anti-rotation valve. The No.1 anti-rotation relay is de-energized at the same time to allow the gear to retract.

¹The C-5A pressure reducer was set at 150 PSIG and the C-5B's pressure reducer is set at 225 PSIG.

SEVEN-PORT BRAKE VALVE—The valve makes up the lower link of the scissors of each MLG and is mechanically operated by the extension/compression of strut at take-off and landing. When the gear is on the ground and the strut compressed to the ground position the valve connects the brake lines from the anti-skid manifold to the wheel brakes. When the strut extends at takeoff, the valve is positioned to block the brake lines from the anti-skid manifold and connects the anti-rotation pressure line to the brakes. See figure 6-7.

WHEEL ANTI-ROTATION SHUTTLE VALVE—The anti-rotation shuttle valve directs pressure to the wheel anti-rotation port of the seven-port valve of each main gear. Inlet pressure for the shuttle valve comes from the anti-rotation pressure reducer valve or the park brake pressure line, depending on which is pressurized. This shuttle valve is located on the side wall of the cargo area adjacent to the right forward wheel well at FS-1340.

SKID CONTROL EXCITER RING AND WHEEL SPEED SENSOR—An exciter ring and wheel speed sensor is installed in the hub of each main wheel. The exciter ring is attached to the air deflation valve inside the wheel hub. The ring rotates with the wheel. The wheel speed sensor is attached to the stationary part of the inflight deflation valve and is held stationary by a slot in the wheel retaining nut. The wheel speed sensor is a magnetic type sealed assembly. Wheel rotation is sensed as notched segments of the exciter ring pass a pair of contact points of the sensor. The series of completed and broken circuit generates a minute alternating current. The signal is transmitted to the control module. Failure of a wheel speed sensor in an open or shorted condition will cause that wheel and the associated wheel to go to freewheeling. See figure 6-8.

DESCRIPTION AND LEADING PARTICULARS OF THE SKID CONTROL SYSTEM

GENERAL—SKID CONTROL DESCRIPTION—The skid control system is a completely automatic, electrically controlled means of preventing each MLG wheel from skidding during brake application. The system consists of a control box, 24 wheel speed detectors, 12 skid control valves, and a skid control and indication system.

- ◆ The control module contains built-in test equipment and indicators for inflight and on ground fault isolation. When the skid control system is deactivated, the brake system is controlled manually by the brake pedals through the dual pilot metering brake control valves. The skid control system is inactive below 12 knots.
- ◆ The skid control system is used with the normal and alternate brake systems. Skid control is accomplished by converting wheel speed to a variable frequency AC voltage. The frequency is directly proportional to the number of wheel revolutions per minute. When wheel deceleration goes beyond a preset limit, or if a wheel locks, the brake pressure to the two paired wheels is dumped. When the wheel spins up again, the brake pressure is reapplied.

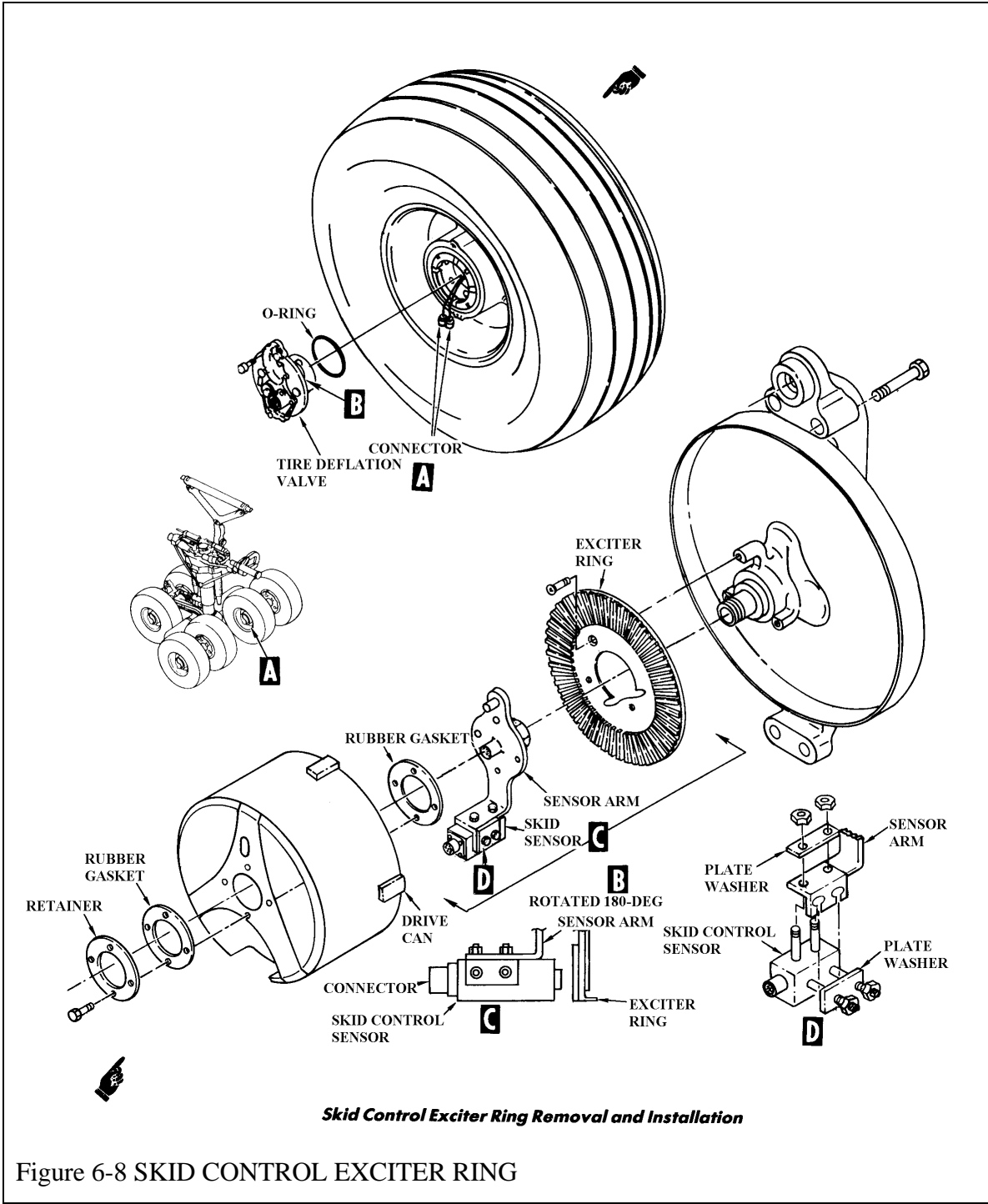

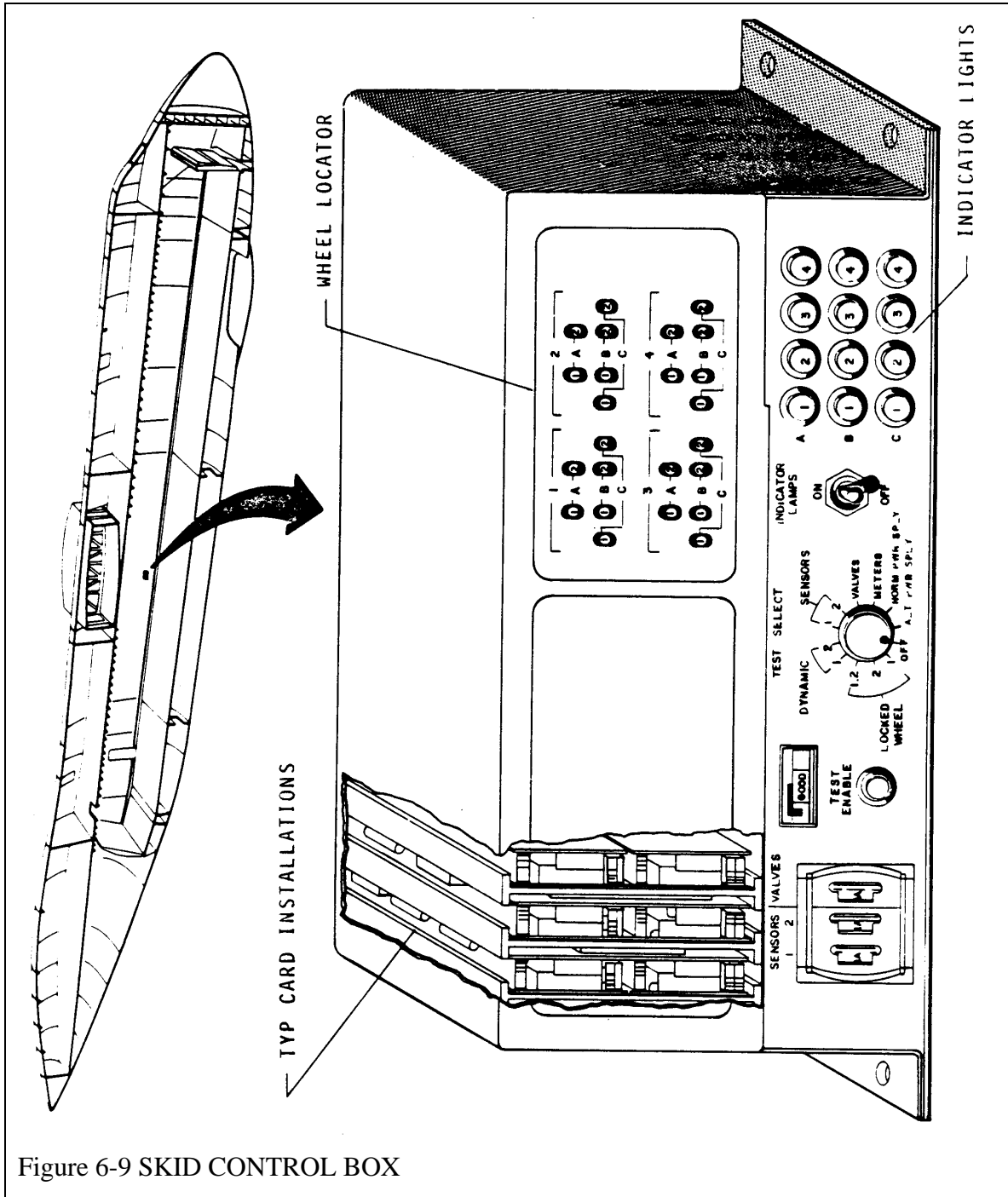

Figure 6-9 SKID CONTROL BOX

ANTI-SKID CONTROL BOX—The anti-skid control box is located on the cargo compartment side wall inboard of the left forward wheel well area. The primary function of the anti-skid control box is to compute braking changes, and based on this information to control braking action. A secondary function is the built-in test equipment, which permits testing of the skid control system without requiring additional test equipment. See figure 6-9.

- ◆ Brake pressure is applied to the wheels in pairs. The anti-skid control box contains 12 dual channel solid-state printed circuit cards, one channel for each wheel speed detector. Each card serves one of the 12 skid control valves. A spare wheel card is stored within the anti-skid control box. The output of two circuits on one card is sent into a logic OR gate. If a skid condition exists in the wheel associated with a particular skid control card, current flows out of the OR gate to the skid control valve, causing the brakes to be released on the two associated wheels.
- ◆ The built-in test card provides a spin-up signal to the skid control circuits. This signal will shut off the skid signal present at the skid control valve. This causes the brakes to be applied and the BRAKES OFF indicator light to go off. A spin-up signal can also be applied to half of the skid control circuits. The application of this signal simulates a locked wheel condition, which causes the brakes to be released. The functions provided by the built-in test equipment are: resistance measurement of skid detectors, resistance measurement of solenoid valves, locked wheel circuit test, deceleration circuit test for each channel, and brake pressure off indicator lights. With the built-in test capability, it is possible to isolate a malfunction to a wheel speed detector, a skid control valve, a brake pressure switch, or a circuit card within the control module.
- ◆ There are 15 fuses located on the bottom of the anti-skid control box. Power for the anti-skid control box comes from either one of two 28 VDC power supplies. If the normal power supply to the anti-skid control box is lost, automatic switching connects the alternate power supply. The anti-skid control box changes the AC signal received from the wheel speed detectors to DC voltage. The DC voltage varies as the wheel speed varies. The comparison of the DC voltage is used to control the skid control valves.
- ◆ The anti-skid control box ensures that the wheels are free to rotate prior to touchdown. If a wheel locks, brake pressure is immediately relieved from this wheel and its paired wheel. The anti-skid control box incorporates a rate threshold circuit, which allows only enough brake pressure to be relieved for a faster reapplication time. The pressure bias modulation circuit allows reapplication of brake pressure gradually after relief to a level just below the previous skid level. The output of the control box is the valve drive circuit. This circuit controls the skid control valves of the brake and skid control manifolds by varying the current to the torque motors, thus controlling the pressure applied to the brake assemblies.
- ◆ A touchdown circuit relay prevents the DET FAILED light from going on while the airplane is airborne.

BRAKE AND SKID CONTROL MANIFOLDS—Four brake and skid control manifolds are incorporated in the brake system. One control manifold serves three paired brake assemblies of each MLG. Each control manifold consists of three skid control valves, three main metering valves, a linear directional control valve, and a park brake selector valve. Each main metering valve is controlled by metered pilot brake control pressure to deliver a proportional brake pressure to a set of brakes. If no pilot metering pressure is applied to the brake control manifold, the main metering valves connect the brakes to the hydraulic system return line.

The linear directional control valve (sometime referred to as directional control valve) supplies pilot-metered pressure from either the normal or alternate supply system to the main metering valves. During normal system operation, the linear directional control valve in each brake and skid control manifold is hydraulically positioned to direct No.4 hydraulic system pressure from the left forward and right forward main landing gear control manifolds to the respective main metering valves. During alternate system operation, the linear directional control valve is positioned to direct No.1 hydraulic system pressure from the left aft and right aft main landing gear control manifolds to the respective main metering valves.

The parking brake selector valve directs accumulator pressure to the brakes whenever the normal or alternate system pilot-metered pressure is not available to the manifold. Each skid control valve electrically controls a main metering valve whenever the skid control system is employed. If the skid control system is not operating, each main metering valve is controlled manually by pilot-metered brake pressure. The manifolds are mounted on the side wall of the cargo area adjacent to the landing gears they serve.

SKID CONTROL VALVE—Three skid control valves are mounted on each brake and skid control manifold. The manifolds are located along the cargo wall inboard of the landing gear positions. Each skid control valve consists of two stages, which modulates the metered brake pressure. The first stage is an electromechanical-type servo valve. This valve controls the second stage by unbalancing pressure applied to each end of its spool-type valve. The first stage receives hydraulic pressure from the brake, metering pilot valve and distributes this pressure to two nozzles located on either side of a flapper. When a no skid condition exists, the flapper valve maintains a neutral position in relation to the nozzles. This condition allows the spool valve to be positioned by the metered pressure to the brake assemblies. At the brake assemblies, the brake disks are compressed until the wheel approaches its maximum deceleration rate. At this point, the control module commands the first stage to move the flapper valve. This blocks one nozzle causing an unbalanced condition. The unbalanced condition moves the spool valve and allows the hydraulic fluid in the brake to flow out a return port.

WHEEL SPEED DETECTOR—The wheel speed detector is comprised of a sensor and exciter ring. The sensor is physically mounted to the inside of the axle and the exciter ring is mounted to the wheel. The sensor is a magnet-type sealed assembly, which detects wheel rotation from notched segments of the exciter ring. See figure 6-8.

Failure of a wheel detector in an open or shorted condition causes the associated brakes of a pair of wheels to dump pressure.

TEST CIRCUIT (THEORY OF OPERATION)—The test circuit for the anti-skid system is contained in two test cards and the control box panel. The test circuit performs the following functions:

- ◆ System test to assure proper operation of anti-skid system components.
- ◆ Fault isolation test to localize a failure LRU in the failed wheel channel.
- ◆ Continuous warning indication to the pilot of an unsafe or failed mode condition.
- ◆ Continuous warning indication to pilot of the status of anti-skid on or off condition and whether a test is being performed.
- ◆ Power transfer from normal to alternate power.
- ◆ Muting and inhibiting to aid in testing.
- ◆ Power regulation to properly operate test circuitry.

SYSTEM TEST—System test can be performed at the copilot's station or the control box located in the cargo compartment. The test basically consists of inserting a test signal into the control circuitry and monitoring light indications that occur as a result of brake pressure switch operation. During test operations, brake pressure must be applied.

The control circuitry is divided into two test groups of 12 circuits each. The circuitry associated with the left wheels of a bogie falls into one test group - group 1, and the right wheels associated circuits fall into the other test group - group 2.

The test signal is furnished from the aircraft's power. A 26-volt, 400 Hz signal used in testing is available to the system when the anti-skid control switch located at the copilot station is positioned to TEST ARM. The test signal is applied to the control circuitry only when a test command signal of 28-volt DC is received from either the copilot's test switch or the test switch located at the control box.

The control box panel contains a test select switch and 12 NO BRAKES test indicators. The switch is used to select the type of test to be performed. The NO BRAKES indicator lights will illuminate when the pressure switch senses a brake pressure dump. Each indicator light is associated with pressure to paired wheels allowing detection of any one channel.

A GO, NO GO indication is available during the copilot's test. All twelve wheel channels for a particular test group will be tested simultaneously. The test switches located at the copilot's station permit a system test for test group 1 or test group 2 wheel circuits individually or simultaneously. The same tests can be performed at the control box panel.

In addition, a dynamic test for either test group 1 or 2 wheel circuits can be performed at the control box panel. During the dynamic tests, the memory line common to the six wheels in a bogie is muted to ground to verify the proper operation of rate circuitry on the wheel card, which is not checked during the other test.

FAULT ISOLATION TEST—Fault isolation test has the function of isolating any failure in the system to a sensor, valve or control circuit associated with a particular wheel

channel. The test consists of checking the channels associated sensor and valve. If the valve and sensor prove good control circuit of the failed circuit channel is assumed to be the failed component. The test consists of energizing the valve or sensor by inserting it into a voltage divider circuit, which, in turn, will produce a drive to the test meter. The test meter indication will show whether the particular sensor or valve has a DC resistance within its resistance tolerance limits.

ANTI-SKID TEST PROCEDURE—The various tests which are provided for by the built-in-test-equipment (BITE) can be controlled at the brake system control panel or at the skid control box. The brake system control panel includes four indicator lights: ANTI-SKID OFF, DET FAILED, BRAKES, and NO BRAKES. A TEST ARM position of the SKID CONTROL switch, along with three test switches, TEST 1, TEST 2, and TEST 3 are located on the brake system control panel to provide control for test procedures.

The ANTI-SKID OFF indicator at the copilot's station will illuminate when: aircraft power is removed from the control box, a test signal is present and test switch 3 is depressed, and when the control box power supply fails. The DETECTOR FAILED indicator will illuminate when a full dump on any brake for three seconds or more is detected.

Indicating and control of the BITE from the anti-skid control box includes the following switches and indicators:

- ◆ Twelve indicator lights used to identify malfunction locations.
- ◆ A two-position, ON-OFF switch used to check the integrity of the indicator lights.
- ◆ A rotary TEST SELECT switch used to select the following test modes:
 - LOCKED WHEEL
 - DYNAMIC
 - SENSORS (Detectors) — used to test individual sensors.
 - VALVES — used to test individual valves.
 - METERS — red / green
 - NORM PWR SUPPLY
 - ALT PWR SUPPLY
- ◆ TEST ENABLE switch which initiates a preselected test mode.
- ◆ SENSORS and VALVES selector switches used for individual selection and testing the wheel detectors (sensors) and valves.
- ◆ A meter used to indicate a good or not good condition of the sensors, valves, or power sources.

FLIGHT STATION GROUND TESTING—The indicator lights marked BRAKES and NO BRAKES on the brake system control panel are used during testing. When the SKID CONTROL switch is placed to the TEST ARM position while no brake pressure is applied, the NO BRAKES light illuminates. Depressing the brake pedals extinguishes the NO BRAKES light and illuminates the BRAKES light. Each of these two lights are connected in series with 12 pressure switches located in the brake lines which supply the 12 indicator lights on the anti-skid control box. If the BRAKES or NO BRAKES light fails to illuminate the malfunction of either a main brake control valve (or valves) or a pressure switch (or switches) can be isolated by examining the lights on the control box.

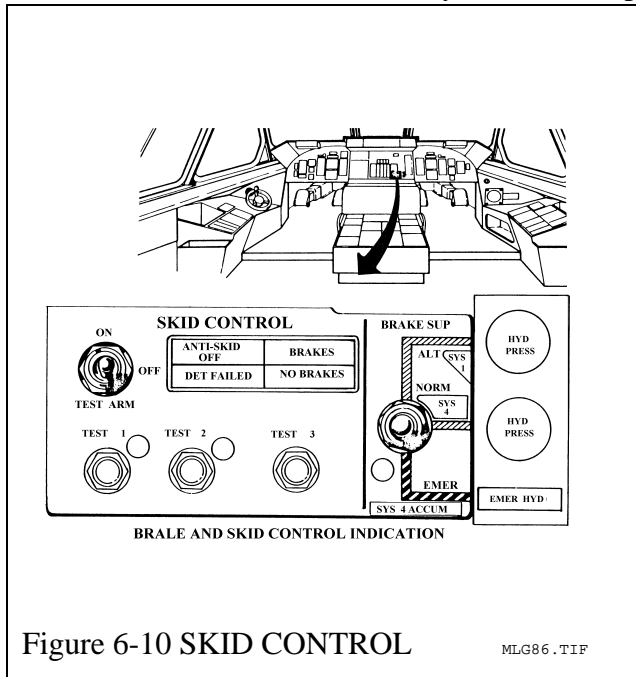

Figure 6-10 SKID CONTROL

MLG86.TIF

OPERATION	ANTI-SKID OFF	DET FAILED	BRAKES	NO BRAKES	SUPPLY	1 = Illuminated 0 = Extinguished	N = Normal A = ALT	REMARKS
Anti-skid control switch off	1	0	0	1				Ground for the ANTI-SKID OFF light is through the de-energized contacts of K4. Ground for the NO BRAKES light is through the 12 brakes pressure switches.
Apply & remove brake pressure several times.	1	0	0-1	1-0				All pressure switches (12) operate properly.
Skid control switch—TEST ARM	0	0	0	1	N A			Either or both control box regulated power supplies are operating, K4 energized. With K4 contacts open and either K3 (400 CPS relay) or k3 contacts open, ground for the ANTI-SKID OFF light is removed. Normal ship DC power supplies the NO BRAKES light.
Apply brakes & hold TEST 1 switch for a minimum of 3 second	0	1	0	1	A			<p>A simulated wheel-rotation signal has been applied to half of each wheel control cards. Each card generates a memory voltage for that wheel pair. The card senses, a lock-wheel condition and produces a valve signal to relieve brake pressure.</p> <p>The DET FAILED light illuminates after 1 valve has a dump signal applied for 3 seconds. The BRAKES UNSAFE light illuminates after 3 valves have a dump signal applied for 1 second.</p> <p>The NO BRAKES light, powered from the ships DC power, illuminates because all brakes have been relieved. Actuation of TEST 1 switch interrupts NORM ships DC power to the NORM regulator in the control box, allowing only operation of the ALT regulator. Regulated power to the card bus is through K1 and K2 contacts.</p>

Release TEST 1. Hold TEST 2 for a minimum of 3 seconds.	0	1	0	1	N	A simulated wheel-rotation signal is now applied to the other half of the control card; same analogy as previous test to dump brakes. Actuation of TEST 2 switch interrupts ALT ships DC power to the ALT regulator in the control box, allowing operation of only the NORM regulator. Regulated power to the card bus is through K2 and K3 contacts. K2 is energized with NORM ships power when Q1 is conducting, supplying a ground for K2.
Hold test 1 and TEST 2.	0	0	1	0	A	Actuation of TEST 1 and TEST 2 supplies a wheel rotation signal to both channels of each control card. As all wheels are simulated to be rotating, application of the brakes is indicated by the BRAKES light. Actuation of TEST 1 and TEST 2 removes NORM ships DC power and allows ALT ships DC power to the ALT regulator in the control box.
Hold TEST 3 switch	1	0	1	0	A	Both NORM and ALT regulators are operating but it is assumed, because of other test, that the B+ bus is fed from the ALT regulator through K3 and K1. K3 is assumed energized because the ANTI-SKID OFF light is illuminated through K3 contacts.
Hold TEST 2 and TEST 3 si- multaneously	1		1	0		The ANTI-SKID OFF light illuminates because K3 relay has energized, removing the NORM regulator output from the bus. The ALT regulator is off because TEST 2 removes ALT ships DC power to it. As there is no B+, K4 de-energizes, grounding the ANTI-SKID OFF light.

With the SKID CONTROL switch in the TEST ARM position, a 400 Hz AC test signal is initiated to simulate wheel spin-up condition. With the simulated spin-up signal made available for test, the TEST 1 switch is depressed impressing the spin-up signal condition to one of the two wheel detector inputs to each dual channel skid control card. The other half of the wheel detector inputs to each card are sensing a locked wheel condition; therefore, the NO BRAKES light should be on regardless of whether the brake pedals are depressed or not. Depressing the TEST 2 switch simulates the other half of the detector units and should provide the same indications as found during TEST 1 operation.

Depressing both TEST 1 and TEST 2 switches at the same time simulates a spin-up condition of all wheels allowing brake application, and brake application by the brake pedals is properly indicated by the BRAKES and NO BRAKES lights and supplemented by the individual lights on the control box.

Depressing TEST 3 simulates a loss of power.

TEST AT SKID CONTROL BOX—At the skid control box, test provisions are installed which can duplicate the tests at the flight station as previously described, with the exception of TEST 3. In addition the performance of each control circuit, continuity of each skid control valve, and the connection to each wheel detector can be tested at the control box. A necessary requirement, in this case, is to have personnel at the flight station to depress the brake pedals, and have voice communication between the two locations, or set the parking brakes. The SKID CONTROL switch must also be in the TEST/ARM position.

The TEST SELECT switch at LOCKED WHEEL position 1, 2, or 1 and 2 together with the 12 brake indicator lights can repeat the test procedures at the flight station.

Next, select the TEST SELECT switch to the VALVES position and the rotary selector on the left end of the panel marked VALVES rotated through its twelve positions. If the meter is not in the green area, then the valve should be replaced. If all valves are good, the faulty control should be replaced.

The TEST SELECT switch also includes DET 1, and DET 2 positions, which are used in conjunction with the sensor rotary selector, and meter for testing of the 24 wheel detectors. A position is provided for checking the meter. The last two places are used for checking the power sources in the control box.

SPIN-UP DETECTOR SYSTEM

A spin-up detector system is utilized to provide wheel spin-up signals to energize the touchdown spin-up relays which control thrust reverser lockout and the ground spoiler handle lockout actuator. The detector system is also used in conjunction with automatic inflight braking operations. The detector system consists of a solid state control module, located on the left cargo compartment sidewall adjacent to the anti-skid control box. The module receives inputs from skid detectors 1A2, 2A1, 3A1, and 4A2. In order for the control module to sense that a spin-up condition exists, 1A2 and 4A2, or 2A1 and 3A1 detectors must transmit a spin signal.

THEORY OF OPERATION—The detector unit is a solid state control module housed in a metal case. The unit can receive three separate types of signal inputs, an input from the skid detectors, a 400 CPS test signal from the test switches located on the copilot's side panel, and a test inhibit ground to prevent a signal from being applied when the anti-skid control box is being tested. The unit is composed of two identical detector sub-assemblies, each of which contains two signal input channels and associated output control signals.

TEST — Two test switches located on the copilot's side console are provided to test the spin-up detector module. Each switch is a three-position, spring-loaded, center-off switch.

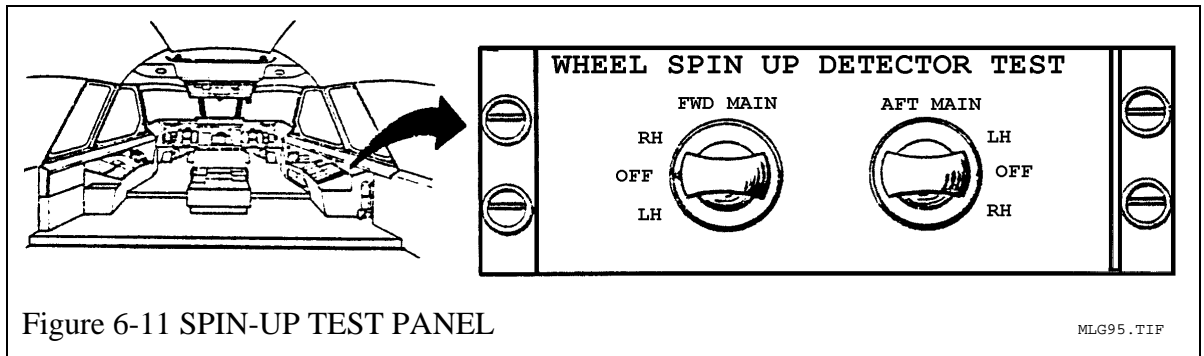

Figure 6-11 SPIN-UP TEST PANEL

MLG95.TIF

One test switch simulates wheel spin-up of the left or right forward main gear, the second switch simulates wheel spin-up of the left or right aft main gear. Testing of the system is accomplished by selecting left forward and right aft, or left aft and right forward test switch positions. Verification of a good test is accomplished by moving the ground spoiler control handle through its travel range while holding the test switches as described above.

Chapter Seven —INFLIGHT TIRE DEFLATION SYSTEM

The deflation system provides for inflight reduction of the tire pressure to a predetermined value allowing the aircraft to operate from airfields of varying runway conditions. An electrically actuated, deflation control assembly is mounted on the hub of each wheel by four cap screws which attach to the threaded inserts in the wheel hub.

The control assembly consists of a support strap, a solenoid valve, a pressure bellows, a pressure switch, a manual pressure-setting device, a slip ring assembly, and an electrical connector. The design of each assembly includes a bracket, which serves for mounting the brake anti-skid sensor, and bosses with threaded inserts for mounting the sensor exciter ring.

The slip-ring housing and anti-skid sensor bracket is keyed to the inside of the axle retainer nut to provide a stationary mount for the housing. The remaining portion of the assembly rotates with the wheel. An electrical connector is provided to permit removal of the control assembly from the aircraft.

A tire deflation control switch located on the upper portion of the flight engineer instrument panel is connected in parallel to the control assemblies, providing for actuation.

OPERATION—Variable actuation pressure settings are obtained by changing the position of the switch with relation to the bellows. This is accomplished by movement of the manual pressure setting handle to one of the available selections.

The support strap is installed over the poppet valve stem of the safety valve and depresses the stem during installation. Depressing the poppet valve stem of the safety valve opens the safety valve and applies pressure directly to the deflation control. Prior to takeoff, each manual pressure setting handle is set to a predetermined (lower) tire pressure required for landing at the support area airfield. The air is contained by the deflation control until the control switch is actuated. Actuation of the control switch applies 28 volts DC to a solenoid through the adjustable, spring-loaded, bellows-controlled microswitch. When the solenoid is energized it opens a spring-loaded poppet-type valve in the control assembly, and inflation air is allowed to escape. Air continues to escape until the pressure drops sufficiently to permit the bellows to move enough to open the microswitch. When the microswitch opens, the holding voltage to the solenoid is removed and the de-activated solenoid allows the poppet valve to be closed by spring pressure.

For a mission requiring inflight deflation, each valve is set to the tire pressure desired for landing at the forward field. During flight, the INFLIGHT TIRE DEFLATION switch on the flight engineer's panel is actuated. All MLG tires will deflate to the previously set pressure.

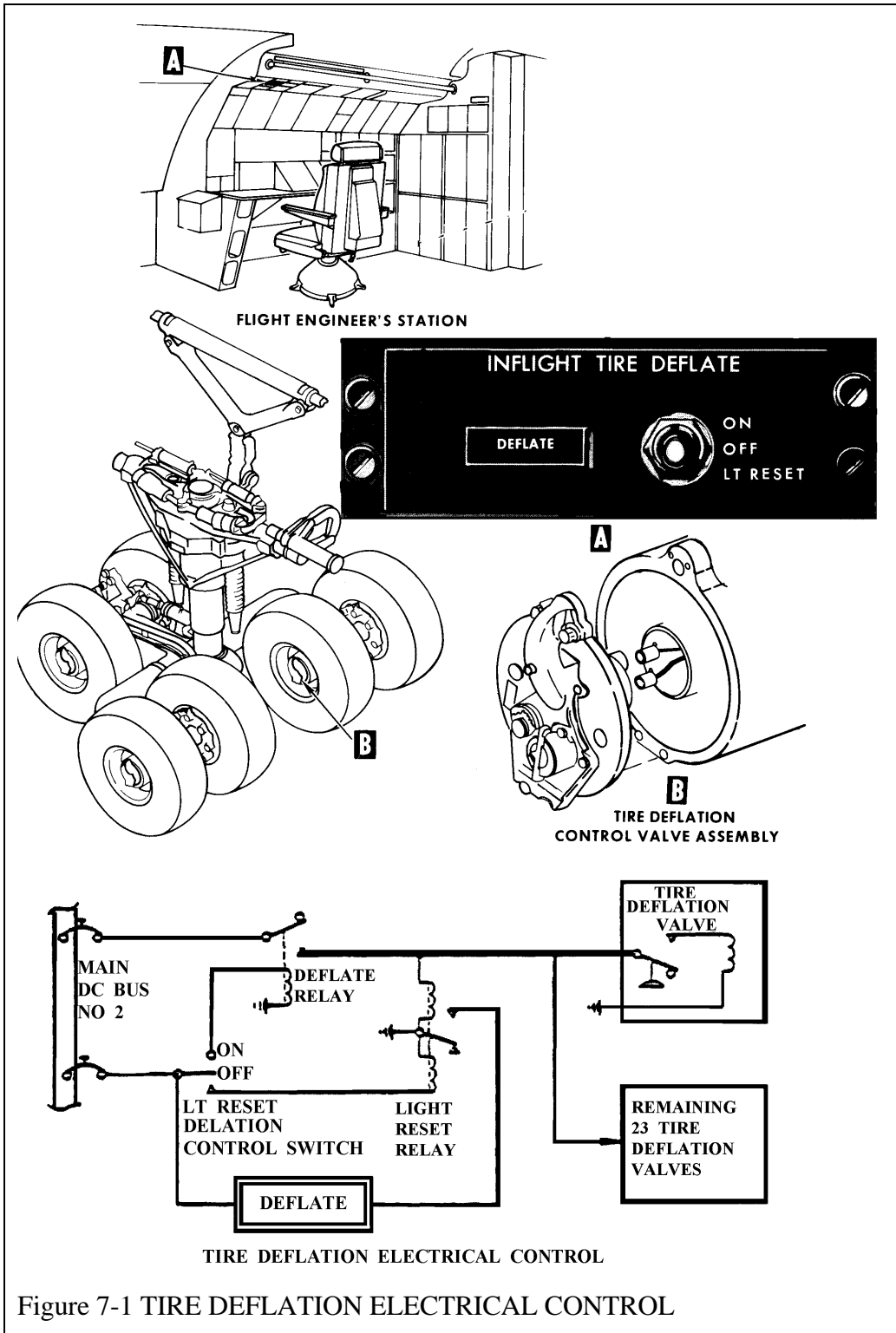

Figure 7-1 TIRE DEFLATION ELECTRICAL CONTROL